

**ATHENS-WAYNE OUTDOOR ASSET DEVELOPMENT
CORPORATION (AWOADC)
8 E. WASHINGTON ST.
ATHENS, OH 45701**

**REQUEST FOR QUOTES
TRAIL MAINTENANCE & ENHANCEMENTS AT
THE BAILEYS TRAIL SYSTEM**

**QUOTE DUE DATE AND TIME:
Friday, May 17th at 2:15pm**

**PROJECT MANAGER:
JESSIE POWERS
OUTDOOR RECREATION COUNCIL OF APPALACHIA
jessie@orcaohio.com
(740) 677-0113**

**KEVIN GREEN
WAYNE NATIONAL FOREST
kevin.green@usda.gov
(560) 620-3565**

**OWNER'S REPRESENTATIVE:
APPLIED TRAILS RESEARCH
JEREMYW@APPLIEDTRAILSRESEARCH.COM
(443) 629-2630**

TABLE OF CONTENTS

I. REQUEST FOR QUOTES	3
Request for Quotes: Important Dates & Information.....	4
Request for Quotes: Details.....	4
II. PROJECT SCOPE	7
III. QUOTE FORMS	9
Quote Forms.....	10
Insurance Required Attachments.....	14
Non-Collusion Affidavit.....	15
Certification Regarding Debarment, Suspension, And Other Responsibility Matters Primary Covered Transactions.....	17
Affidavit In Compliance With Section 3517.13 Of The Ohio Revised Code.....	19
Additional Certifications.....	21
Sales And Use Tax Contractor’s Exemption Certificate.....	22
DMA Public Employment.....	23
Form W-9.....	26
Contractor Qualifications.....	31
IV. PROJECT SPECIFICATIONS	32
Division 1 - General Requirements.....	33
Division 2 - Earthwork.....	37
Division 3 - Completion Requirements.....	38
Division 4 - Construction Specifications.....	39
V. GENERAL PROVISIONS	41
ATTACHMENT A. BAILEYS CONSTRUCTION DOCUMENTS	49
ATTACHMENT B. FRONTCOUNTRY TRAIL SPECIFICATIONS	62
ATTACHMENT C. ADAPTIVE MOUNTAIN BIKE TRAIL SPECIFICATIONS	65
ATTACHMENT D. CLEAN AIR AND FEDERAL WATER POLLUTION CONTROL ACT	71
ATTACHMENT E. MAPS	74
ATTACHMENT F. SAMPLE CONTRACT FOR CONSTRUCTION SERVICES	77
ATTACHMENT G. DAVIS-BACON WAGE DETERMINATIONS	86

TRAIL MAINTENANCE AND ENHANCEMENTS AT THE BAILEYS TRAIL SYSTEM
REQUEST FOR QUOTES
ATHENS-WAYNE OUTDOOR ASSET DEVELOPMENT CORPORATION

I. REQUEST FOR QUOTES

TRAIL MAINTENANCE AND ENHANCEMENTS AT THE BAILEYS TRAIL SYSTEM
REQUEST FOR QUOTES
ATHENS-WAYNE OUTDOOR ASSET DEVELOPMENT CORPORATION

**REQUEST FOR QUOTES
ATHENS-WAYNE OUTDOOR ASSET DEVELOPMENT
CORPORATION (AWOADC) & OUTDOOR RECREATION
COUNCIL OF APPALACHIA (ORCA)
TRAIL MAINTENANCE AND ENHANCEMENTS AT THE
BAILEYS TRAIL SYSTEM**

Request for Quotes: Important Dates & Information

Project Name: Trail Maintenance and Enhancements at the Baileys Trail System

Quote Submission Deadline: Friday, May 17th at 2:15pm EST

Pre-Quote Meeting:

Virtual on Friday, April 26th at 11:00am EST
Email info@orcaohio.com to obtain meeting link

Deliver or Mail Quote Electronically or To:

Outdoor Recreation Council of Appalachia C/O Ms. Jessie Powers
8 E. Washington St. First Floor City Hall
Athens, OH 45701

Quote Submission Requirements:

Quotes can be provided emailed to: Jeremy Wimpey (jeremyw@appliedtrailsresearch.com), Jessie Powers (jessie@orcaohio.com), & Kevin Green (kevin.green@usda.gov), or delivered in sealed envelope labeled "Trail Maintenance and Enhancements at the Baileys Trail System" by Friday, May 17th at 2:15pm EST.

Request for Quotes: Details

1. Quotes for TRAIL MAINTENANCE AND ENHANCEMENTS AT THE BAILEYS TRAIL SYSTEM will be received and time date stamped by the OUTDOOR RECREATION COUNCIL OF APPALACHIA, 8 E. WASHINGTON ST. FIRST

TRAIL MAINTENANCE AND ENHANCEMENTS AT THE BAILEYS TRAIL SYSTEM
REQUEST FOR QUOTES
ATHENS-WAYNE OUTDOOR ASSET DEVELOPMENT CORPORATION

FLOOR CITY HALL, ATHENS, OH 45701 until **Friday, May 17th at 2:15pm**, at which time they will be publicly opened and read on site. Unit pricing will not be disclosed at the quote opening. Quotes received after the above-stated date and time will not be considered.

2. A pre-quote meeting will be held virtually on **Friday, April 26th at 11:00am** EST; email info@orcaohio.com to obtain a meeting link. Contractor questions not answered within this or the incorporated documents can be addressed via email to Jeremy Wimpey (jeremyw@appliedtrailsresearch.com), Jessie Powers (jessie@orcaohio.com), & Kevin Green (kevin.green@usda.gov) prior to **May 1st at 4:00pm**. Responses, Addenda, and Pre-Quote recording will be posted to ORCA's website (www.orcaohio.com) prior to **Friday, May 3rd**.
3. Quote Providers must acknowledge receipt of all Addenda.
4. No quote will be considered complete which is not submitted with SEALED ENVELOPES labeled "TRAIL MAINTENANCE AND ENHANCEMENTS AT THE BAILEYS TRAIL SYSTEM" (one (1) original and one (1) copy), containing the requisite information as required in III. QUOTE FORMS, and signed by a proper official of the company providing the quote, in the space provided therefore. Facsimile or emailed quotes will not be accepted.
5. No quote will be considered which modifies in any manner any of the general provisions, specifications or the bid form.
6. In case of an error in the extension of prices in the quote the unit prices will govern.
7. The ORCA/AWOADC takes no responsibility for delivery of quotes through mail.
8. The Quote Provider further understands that the ORCA/AWOADC shall determine in its sole discretion the lowest responsive and responsible Quote Provider, and the ORCA/AWOADC may reject any and all quotes or make substitution, waive defects it deems unsubstantial in any quote, and that if awards are made, the ORCA/AWOADC will award the quote in the best interest of the ORCA/AWOADC. Award of quote is subject to funding appropriation for this project. The ORCA/AWOADC reserves the right to reject any or/all quotes, to waive any formality, and/or accept the quote deemed in the best interest of the ORCA/AWOADC. The project components will be awarded to the lowest responsive and responsible quote providers.

TRAIL MAINTENANCE AND ENHANCEMENTS AT THE BAILEYS TRAIL SYSTEM
REQUEST FOR QUOTES
ATHENS-WAYNE OUTDOOR ASSET DEVELOPMENT CORPORATION

9. A quote will be considered “Responsible” if, at the sole discretion of ORCA/AWOADC, its agents, and property owner (Wayne National Forest), the CONTRACTOR QUALIFICATIONS provide reasonable assurance that a high-quality, timely-delivered product based on information supplied by the Quote Provider and reference providers will be delivered by the CONTRACTOR.
10. A quote that is in the possession of the ORCA/AWOADC may be altered by a letter bearing the signature and name of the person authorized for providing quotes, provided it is received prior to the time and date of the quote opening; this will only be accepted by mail or email. It is the quote provider’s responsibility to confirm receipt of this alteration by the ORCA/AWOADC.
11. A quote that is in the possession of the ORCA/AWOADC may be withdrawn by the quote provider up to the time and date of the quote opening. Quotes may not be withdrawn for a period of 90 days after the quote opening.
12. Each quote shall contain the full name and address of each person or company interested in the same. A performance bond of one hundred percent (100%) of the amount of the contract with a satisfactory surety company, conditioned according to law, will be required for the faithful performance of the contract.
13. The ORCA/AWOADC hereby notifies all prospective quote providers it will affirmatively assure that minority business enterprises will be afforded full and equal opportunity to submit bids in response to this invitation and are specifically encouraged to do so. The ORCA/AWOADC further assures that it will not discriminate against anyone on the grounds of race, sex, age, color or national origin or disability in consideration for an award.
14. Attention of quote providers is called to all of the requirements contained in this quote packet, particularly to the Federal Davis Bacon Wages, various insurance requirements, various equal opportunity provisions, and the requirement for a performance bond for 100% of the contract price.

Dated this **Friday, April 19, 2024**.

TRAIL MAINTENANCE AND ENHANCEMENTS AT THE BAILEYS TRAIL SYSTEM
REQUEST FOR QUOTES
ATHENS-WAYNE OUTDOOR ASSET DEVELOPMENT CORPORATION

II. PROJECT SCOPE

TRAIL MAINTENANCE AND ENHANCEMENTS AT THE BAILEYS TRAIL SYSTEM
REQUEST FOR QUOTES
ATHENS-WAYNE OUTDOOR ASSET DEVELOPMENT CORPORATION

**ATHENS-WAYNE OUTDOOR ASSET DEVELOPMENT CORPORATION (AWOADC)
&
OUTDOOR RECREATION COUNCIL OF APPALACHIA (ORCA)
PROJECT SCOPE**

TRAIL MAINTENANCE AND ENHANCEMENTS AT THE BAILEYS TRAIL SYSTEM

Completion of an on-site investigation of existing conditions, furnishing all labor, equipment, supplies and materials in performing all operations necessary for the complete and proper completion of project scope activities. The project scope includes widening and maintenance tasks across 5.35 miles of trail, including:

- 1) 1000 linear feet of tread reconstruction to 60" width
- 2) 27,250 linear feet of tread reconstruction to 48" width
- 3) 115 broad based drainage dips
- 4) 9 insloped turn improvements
- 5) 480 sq. ft of rock armored tread
- 6) 190 linear ft. of raised tread
- 7) 2 Arched Culvert (96" long x ½ 48" diameter) replacements
- 8) 28 Cu. Yd. aggregate surface addition

III. QUOTE FORMS

The following pages contain documents that must be completed and submitted by the quote provider at the time of quote:

- Quote Forms
- Insurance Required Attachment
- Quote Guaranty And Contract Bond Forms
- Non-Collusion Affidavit
- Certification Regarding Debarment, Suspension, And Other Responsibility Matters
Primary Covered Transactions
- Affidavit In Compliance With Section 3517.13 Of The Ohio Revised Code
- Additional Certifications
- Sales And Use Tax Contractor's Exemption Certificate
- DMA Public Employment
- Form W-9
- Contractor Qualifications

Quote Forms

**Athens-Wayne Outdoor Asset Development Corporation &
Outdoor Recreation Council Of Appalachia
Trail Maintenance and Enhancements at the Baileys Trail System**

1. BY SUBMISSION OF A QUOTE, THE QUOTE PROVIDER CERTIFIES:
 - a. Prices in this quote have been arrived at independently, without consultation, communication or agreement for the purpose of restricting competition.
 - b. No attempt has been made nor will be by the quote provider to induce any other person or firm to submit a quote for the purpose of restricting competition.
 - c. The person signing this quote certifies that he/she is authorized to represent the company and is legally responsible for the decision as to the price and supporting documentation provided as a result of this advertisement.
 - d. Quote Provider will comply with all Federal regulations, policies, guidelines and requirements.

2. GENERAL INFORMATION

Company Name: _____ Phone: _____

Signatory's Name: _____

Signature & Title: _____ (Date)

Mailing Address: _____

City: _____ State: _____ Zip: _____

Email Address: _____

SSN/Employer Identification Number: _____

TRAIL MAINTENANCE AND ENHANCEMENTS AT THE BAILEYS TRAIL SYSTEM
REQUEST FOR QUOTES
ATHENS-WAYNE OUTDOOR ASSET DEVELOPMENT CORPORATION

3. OWNERSHIP AND CONTROL

Quote Provider's Legal Structure: _____

- | | |
|--|--|
| <input type="checkbox"/> Sole Proprietorship | <input type="checkbox"/> General Partnership |
| <input type="checkbox"/> Corporation | <input type="checkbox"/> Limited Partnership |
| <input type="checkbox"/> Limited Liability | <input type="checkbox"/> Other: _____ |

4. TIMELINE

Proposed Construction Start Date: _____

5. QUOTE TABULATION

Contractor shall price work according to the schedules below.

The Quote Provider understands ORCA/AWOADC Reserves the right to reject any or all quotes and to waive any informalities in the quote process. ORCA/AWOADC Reserves the right to enter into contract negotiations for up to the full project scope of work depending on funding availability.

The quote provider agrees that this quote shall be good and may not be withdrawn for a period of 90 calendar days after the scheduled closing time for receiving quotes.

Federal Prevailing Wages Rates apply.

\

TRAIL MAINTENANCE AND ENHANCEMENTS AT THE BAILEYS TRAIL SYSTEM
 REQUEST FOR QUOTES
 ATHENS-WAYNE OUTDOOR ASSET DEVELOPMENT CORPORATION

WORK ITEM	UNIT	UNIT PRICE	EST. QUANTITY	SUBTOTAL
Tread Reconstruction (to 60" width)	Lin. Ft.		1,000	
Tread Reconstruction (to 48" width)	Lin. Ft.		27,250	
Broad based Drainage Dip	Each		115	
Insloped Turn Improvement	Each		9	
Rock Armor Tread	Sq. Ft		480	
Raised Tread	Lin Ft.		190	
Arched Culvert (96" long x 1/2 48" Diameter) Replacement	Each		2	
Aggregate Surface Addition	Cu. Yd.		28	
Berm Re-Establish	Lin. Ft		70	
Reconfigure Trail Junction	Lump Sum		1	
Mobilization	Lump Sum		1	
TOTAL				

QUOTE TOTAL: _____

QUOTE TOTAL IN WORDS: _____

THE QUOTE PROVIDER'S TOTAL ABOVE IS HIS TOTAL QUOTE BASED ON HIS UNIT PRICES AND LUMP SUM PRICES AND THE ESTIMATED QUANTITIES SHOWN ON THE PLANS. THIS FIGURE IS FOR INFORMATION ONLY AT THE TIME OF OPENING QUOTES. THE OWNER WILL MAKE THE TABULATION FROM THE UNIT PRICES AND LUMP SUM PRICES QUOTE. IF THERE IS AN ERROR IN THE TOTAL BY THE QUOTE PROVIDER, IT SHALL BE CHANGED AS ONLY THE UNIT PRICES AND LUMP SUM PRICES SHALL

TRAIL MAINTENANCE AND ENHANCEMENTS AT THE BAILEYS TRAIL SYSTEM
REQUEST FOR QUOTES
ATHENS-WAYNE OUTDOOR ASSET DEVELOPMENT CORPORATION

GOVERN.

FEDERAL I.D. NO.: _____

DUNS I.D. NO.: _____

CONTRACTOR COMPLIANCE CERTIFICATION NO. (IF APPLICABLE):

QUOTE ADDENDUM

ADDENDUM No. _____ RECEIVED (SIGN WHEN APPLICABLE):

_____  _____
Signature Date

Print Name, Co. Title

TRAIL MAINTENANCE AND ENHANCEMENTS AT THE BAILEYS TRAIL SYSTEM
REQUEST FOR QUOTES
ATHENS-WAYNE OUTDOOR ASSET DEVELOPMENT CORPORATION

Insurance Required Attachments

A. Please Attach Proof of Insurance.

TRAIL MAINTENANCE AND ENHANCEMENTS AT THE BAILEYS TRAIL SYSTEM
REQUEST FOR QUOTES
ATHENS-WAYNE OUTDOOR ASSET DEVELOPMENT CORPORATION

Non-Collusion Affidavit

State of: Ohio

County of: ATHENS

QUOTE Identification: TRAIL MAINTENANCE AND ENHANCEMENTS AT THE
BAILEYS TRAIL SYSTEM

CONTRACTOR: _____

being duly sworn, deposed and says that he is _____,
(Sole owner, a partner, president, secretary, etc.) of _____,
the party making the foregoing QUOTE; that such QUOTE is not made in the interest of or on
behalf of any undisclosed person, partnership, company, association, organization, or
corporation; that such QUOTE is genuine and not collusive or sham; that said QUOTE
PROVIDER has not directly or indirectly induced or solicited any other QUOTE PROVIDER to
put in a fake or sham QUOTE and has not directly or indirectly colluded, conspired, connived,
or agreed with any QUOTE PROVIDER or anyone else to put in a sham BID, or that any one
shall refrain from bidding; that said QUOTE PROVIDER has not in any manner directly or
indirectly, sought by agreement, communication or conference with anyone to fix the QUOTE
price of said QUOTE PROVIDER or of any other QUOTE PROVIDER, or to fix any overhead,
profit, or cost element of such QUOTE price, or of that of any other QUOTE PROVIDER, or to
secure any advantage against the OWNER awarding the contract or anyone interested in the
proposed contract; that all statements contained in such QUOTE are true; and, further, that said
QUOTE PROVIDER has not, directly or indirectly, submitted his QUOTE price or any
breakdown thereof, or the contents thereof, or divulged information or data relative thereto, or
paid and will not pay any fee in connection therewith, to any corporation, partnership, company,
association, organization, QUOTE depository, or to any member or agent thereof, or to any other
individual except to such person or persons as have a partnership or other financial interest with
said QUOTE PROVIDER in his general business.

Signed: _____ 

TRAIL MAINTENANCE AND ENHANCEMENTS AT THE BAILEYS TRAIL SYSTEM
REQUEST FOR QUOTES
ATHENS-WAYNE OUTDOOR ASSET DEVELOPMENT CORPORATION

Subscribed and sworn to before me this day _____ of _____, _____ .

SIGN HERE

Notary Public

My Commission Expires

SEAL

Certification Regarding Debarment, Suspension, And Other Responsibility Matters Primary Covered Transactions

This certification is required by the regulations implementing Executive Order 12549, Debarment and Suspension, 34 CFR Part 85, Section 85.510, Participant's responsibilities. The regulations were published as Part VII of the May 26, 1988 Federal Register (pages 19160 - 19211). Copies of the regulation may be obtained by contacting the U.S. Department of Education, Grants and Contracts Service, 400 Maryland Avenue, S.W. (Room 3633 GSA Regional Office Building No. 3), Washington, DC. 20202-4725, telephone (202) 732-2505.

(1) The prospective primary participant certifies to the best of its knowledge and belief, that it and its principals:

(a) Are not presently debarred, suspended, proposed for debarment, declared ineligible, or voluntarily excluded from covered transactions by any Federal department or agency;

(b) Have not within a three-year period preceding this proposal been convicted of or had a civil judgment rendered against them for commission of fraud or a criminal offense in connection with obtaining, attempting to obtain, or performing a public (Federal, State, or Local) transaction or contract under a public transaction; violation of Federal or State antitrust statutes or commission of embezzlement, theft, forgery, bribery, falsification or destruction of records, making false statements, or receiving stolen property;

(c) Are not presently indicted for or otherwise criminally or civilly charged by a governmental entity (Federal, State, or Local) with commission of any of the offenses enumerated in paragraph (1)(b) of this certification; and

(d) Have not within a three-year period preceding this application/proposal had one or more public transactions (Federal, State, or Local) terminated for cause or default.

(2) Where the prospective primary participant is unable to certify to any of the statements in this certification, such prospective participant shall attach an explanation to this proposal.

Organization Name

TRAIL MAINTENANCE AND ENHANCEMENTS AT THE BAILEYS TRAIL SYSTEM
REQUEST FOR QUOTES
ATHENS-WAYNE OUTDOOR ASSET DEVELOPMENT CORPORATION

TRAIL MAINTENANCE AND ENHANCEMENTS AT THE BAILEYS TRAIL SYSTEM
PR/Award Number or Project Name

Name and Title of Authorized Representative

SIGN HERE

Signature

Date

ED Form GCS-008 (REV.12/88)

Affidavit In Compliance With Section 3517.13 Of The Ohio Revised Code

STATE OF OHIO

COUNTY OF ATHENS, SS: _____

Personally appeared before me the undersigned, as an individual or as a representative of _____ (Name of Entity) for a contract for TRAIL MAINTENANCE AND ENHANCEMENTS AT THE BAILEYS TRAIL SYSTEM (Type of Product or Service) to be let by the County of ATHENS, who, being duly cautioned and sworn, makes the following statement with respect to prohibited activities constituting a conflict of interest or other violations under Ohio Revised Code Section 3517.13, and further states that the undersigned has the authority to make the following representation on behalf of himself or of the business entity:

1. That none of the following has individually made within the two previous calendar years and that, if awarded a contract for the purchase of goods or services in excess of \$500.00, none of the following individually will make, beginning on the date the contract is awarded and extending until one year following the conclusion of the contract, as an individual, one or more campaign contributions totaling in excess of \$1,000.00, to any member of the ATHENS, County Board of Commissioners or their individual campaign committees:
 - a. myself;
 - b. any partner or owner or shareholder of the partnership (if applicable);
 - c. any owner of more than 20% of the corporation or business trust (if applicable);
 - d. each spouse of any person identified in (a) through (c) of this section;
 - e. each child seven years of age to seventeen years of age of any person identified in divisions (a) through (c) of this section (only applicable to contributions made on or after January 1, 2007).

2. That none of the following have collectively made since January 1, 2007 and that, if awarded a contract for the purchase of goods or services in excess of \$500.00, none of the following collectively will make, beginning on the date the contract is awarded and extending until one year following the conclusion of the contract, one or more campaign contributions totaling in excess of \$2,000.00, to any member of the ATHENS, County Board of Commissioners or their individual campaign committees:
 - a. myself;

TRAIL MAINTENANCE AND ENHANCEMENTS AT THE BAILEYS TRAIL SYSTEM
REQUEST FOR QUOTES
ATHENS-WAYNE OUTDOOR ASSET DEVELOPMENT CORPORATION

- b. any partner or owner or shareholder of the partnership (if applicable);
- c. any owner of more than 20% of the corporation or business trust (if applicable);
- d. each spouse of any person identified in (a) through (c) of this section;
- e. each child seven years of age to seventeen years of age of any person identified in divisions (a) through (c) of this section (only applicable to contributions made on or after January 1, 2007).

Signature 

Title

Sworn to before me and subscribed in my presence this _____ day of _____, _____.

Notary Public 

My Commission Expires

SEAL

Additional Certifications

Project Name: TRAIL MAINTENANCE AND ENHANCEMENTS AT THE BAILEYS TRAIL SYSTEM

I certify that my company has the *facilities* to complete this job.

I certify that my company has the *labor force* to complete this job.

I certify that my company has the *equipment* to complete this job.

I certify that my company has the *administrative capacity* to complete this job.

I certify that my company has the *knowledge* to complete this job.

I certify that my company maintains a *drug free workplace*.

Name and Title of Authorized Representative

Signature & Date

SIGN HERE



Sales and Use Tax Contractor's Exemption Certificate

Identification of Contract:

Contractee's (owner's) name _____

Exact location of job/project _____

Name of job/project as it appears
on contract documentation _____

The undersigned hereby certifies that the tangible personal property purchased under this exemption from:

_____ Vendor's name

was purchased for incorporation into:

<input type="checkbox"/>	Real property under a construction contract with the United States government, its agencies, the state of Ohio, or an Ohio political subdivision;	<input type="checkbox"/>	Real property that is owned, or will be accepted for ownership at the time of completion, by the United States government, its agencies, the state of Ohio or an Ohio political subdivision;
<input type="checkbox"/>	A horticulture structure or livestock structure for a person engaged in the business of horticulture or producing livestock;	<input type="checkbox"/>	A house of public worship or religious education;
<input type="checkbox"/>	A building used exclusively for charitable purposes by a nonprofit organization operated exclusively for charitable purposes as defined in Ohio Revised Code (R.C.) section 5739.02(B)(12);	<input type="checkbox"/>	A building under a construction contract with an organization exempt from taxation under section 501(c)(3) of the Internal Revenue Code of 1986 when the building is to be used exclusively for the organization's exempt purposes;
<input type="checkbox"/>	The original construction of a sports facility under R.C. section 307.696;	<input type="checkbox"/>	A hospital facility entitled to exemption under R.C. section 140.08;
<input type="checkbox"/>	Real property outside this state if such materials and services, when sold to a construction contractor in the state in which the real property is located for incorporation into real property in that state, would be exempt from a tax on sales levied by that state;	<input type="checkbox"/>	Building and construction materials and services sold for incorporation into real property comprising a convention center that qualifies for property tax exemption under R.C. 5709.084 (until one calendar year after the construction is completed).

This certificate may be used by a contractee or subcontractor when buying materials for a construction contract where the owner/contractee has claimed one of the above exemptions. This certificate covers all sales of materials by the above-named vendor to the contractor or subcontractor for this particular construction contract only.

Contractor/subcontractor

Name

Signed by

Title

Street address

City, state, ZIP code

Date



PUBLIC EMPLOYMENT

In accordance with section 2909.34 of the Ohio Revised Code

DECLARATION REGARDING MATERIAL ASSISTANCE/NONASSISTANCE TO A TERRORIST ORGANIZATION

This form serves as a declaration of the provision of material assistance to a terrorist organization or organization that supports terrorism as identified by the U.S. Department of State Terrorist Exclusion List (see the Ohio Homeland Security Division website for a reference copy of the Terrorist Exclusion List).

Any answer of "yes" to any question, or the failure to answer "no" to any question on this declaration shall serve as a disclosure that material assistance to an organization identified on the U.S. Department of State Terrorist Exclusion List has been provided. Failure to disclose the provision of material assistance to such an organization or knowingly making false statements regarding material assistance to such an organization is a felony of the fifth degree.

For the purposes of this declaration, "material support or resources" means currency, payment instruments, other financial securities, funds, transfer of funds, and financial services that are in excess of one hundred dollars, as well as communications, lodging, training, safe houses, false documentation or identification, communications equipment, facilities, weapons, lethal substances, explosives, personnel, transportation, and other physical assets, except medicine or religious materials.

Form with fields: LAST NAME, FIRST NAME, MIDDLE INITIAL, HOME ADDRESS, CITY, STATE, ZIP, COUNTY, HOME PHONE, WORK PHONE

DECLARATION

In accordance with division (A)(2)(b) of section 2909.32 of the Ohio Revised Code

For each question, indicate either "yes," or "no" in the space provided. Responses must be truthful to the best of your knowledge.

- 1. Are you a member of an organization on the U.S. Department of State Terrorist Exclusion List?
2. Have you used any position of prominence you have with any country to persuade others to support an organization on the U.S. Department of State Terrorist Exclusion List?
3. Have you knowingly solicited funds or other things of value for an organization on the U.S. Department of State Terrorist Exclusion List?

PUBLIC EMPLOYMENT - CONTINUED

4. Have you solicited any individual for membership in an organization on the U.S. Department of State Terrorist Exclusion List?
 Yes No
5. Have you committed an act that you know, or reasonably should have known, affords "material support or resources" to an organization on the U.S. Department of State Terrorist Exclusion List?
 Yes No
6. Have you hired or compensated a person you knew to be a member of an organization on the U.S. Department of State Terrorist Exclusion List, or a person you knew to be engaged in planning, assisting, or carrying out an act of terrorism?
 Yes No

In the event of a denial of public employment due to a positive indication that material assistance has been provided to a terrorist organization, or an organization that supports terrorism as identified by the U.S. Department of State Terrorist Exclusion List, a review of the denial may be requested. The request must be sent to the Ohio Department of Public Safety's Division of Homeland Security. The request forms and instructions for filing can be found on the Ohio Homeland Security Division website.

CERTIFICATION

I hereby certify that the answers I have made to all of the questions on this declaration are true to the best of my knowledge. I understand that if this declaration is not completed in its entirety, it will not be processed and I will be automatically disqualified. I understand that I am responsible for the correctness of this declaration. I understand that failure to disclose the provision of material assistance to an organization identified on the U.S. Department of State Terrorist Exclusion List, or knowingly making false statements regarding material assistance to such an organization is a felony of the fifth degree. I understand that any answer of "yes" to any question, or the failure to answer "no" to any question on this declaration shall serve as a disclosure that material assistance to an organization identified on the U.S. Department of State Terrorist Exclusion List has been provided by myself or my organization.

X

Signature

Date

By signing the filled-out form, you:

1. Certify that the TIN you are giving is correct (or you are waiting for a number to be issued),
2. Certify that you are not subject to backup withholding, or
3. Claim exemption from backup withholding if you are a U.S. exempt payee. If applicable, you are also certifying that as a U.S. person, your allocable share of any partnership income from a U.S. trade or business is not subject to the withholding tax on foreign partners' share of effectively connected income, and
4. Certify that FATCA code(s) entered on this form (if any) indicating that you are exempt from the FATCA reporting, is correct. See *What is FATCA reporting*, later, for further information.

Note: If you are a U.S. person and a requester gives you a form other than Form W-9 to request your TIN, you must use the requester's form if it is substantially similar to this Form W-9.

Definition of a U.S. person. For federal tax purposes, you are considered a U.S. person if you are:

- An individual who is a U.S. citizen or U.S. resident alien;
- A partnership, corporation, company, or association created or organized in the United States or under the laws of the United States;
- An estate (other than a foreign estate); or
- A domestic trust (as defined in Regulations section 301.7701-7).

Special rules for partnerships. Partnerships that conduct a trade or business in the United States are generally required to pay a withholding tax under section 1446 on any foreign partners' share of effectively connected taxable income from such business. Further, in certain cases where a Form W-9 has not been received, the rules under section 1446 require a partnership to presume that a partner is a foreign person, and pay the section 1446 withholding tax. Therefore, if you are a U.S. person that is a partner in a partnership conducting a trade or business in the United States, provide Form W-9 to the partnership to establish your U.S. status and avoid section 1446 withholding on your share of partnership income.

In the cases below, the following person must give Form W-9 to the partnership for purposes of establishing its U.S. status and avoiding withholding on its allocable share of net income from the partnership conducting a trade or business in the United States.

- In the case of a disregarded entity with a U.S. owner, the U.S. owner of the disregarded entity and not the entity;
- In the case of a grantor trust with a U.S. grantor or other U.S. owner, generally, the U.S. grantor or other U.S. owner of the grantor trust and not the trust; and
- In the case of a U.S. trust (other than a grantor trust), the U.S. trust (other than a grantor trust) and not the beneficiaries of the trust.

Foreign person. If you are a foreign person or the U.S. branch of a foreign bank that has elected to be treated as a U.S. person, do not use Form W-9. Instead, use the appropriate Form W-8 or Form 8233 (see Pub. 515, *Withholding of Tax on Nonresident Aliens and Foreign Entities*).

Nonresident alien who becomes a resident alien. Generally, only a nonresident alien individual may use the terms of a tax treaty to reduce or eliminate U.S. tax on certain types of income. However, most tax treaties contain a provision known as a "saving clause." Exceptions specified in the saving clause may permit an exemption from tax to continue for certain types of income even after the payee has otherwise become a U.S. resident alien for tax purposes.

If you are a U.S. resident alien who is relying on an exception contained in the saving clause of a tax treaty to claim an exemption from U.S. tax on certain types of income, you must attach a statement to Form W-9 that specifies the following five items.

1. The treaty country. Generally, this must be the same treaty under which you claimed exemption from tax as a nonresident alien.
2. The treaty article addressing the income.
3. The article number (or location) in the tax treaty that contains the saving clause and its exceptions.
4. The type and amount of income that qualifies for the exemption from tax.
5. Sufficient facts to justify the exemption from tax under the terms of the treaty article.

Example. Article 20 of the U.S.-China income tax treaty allows an exemption from tax for scholarship income received by a Chinese student temporarily present in the United States. Under U.S. law, this student will become a resident alien for tax purposes if his or her stay in the United States exceeds 5 calendar years. However, paragraph 2 of the first Protocol to the U.S.-China treaty (dated April 30, 1984) allows the provisions of Article 20 to continue to apply even after the Chinese student becomes a resident alien of the United States. A Chinese student who qualifies for this exception (under paragraph 2 of the first protocol) and is relying on this exception to claim an exemption from tax on his or her scholarship or fellowship income would attach to Form W-9 a statement that includes the information described above to support that exemption.

If you are a nonresident alien or a foreign entity, give the requester the appropriate completed Form W-8 or Form 8233.

Backup Withholding

What is backup withholding? Persons making certain payments to you must under certain conditions withhold and pay to the IRS 24% of such payments. This is called "backup withholding." Payments that may be subject to backup withholding include interest, tax-exempt interest, dividends, broker and barter exchange transactions, rents, royalties, nonemployee pay, payments made in settlement of payment card and third party network transactions, and certain payments from fishing boat operators. Real estate transactions are not subject to backup withholding.

You will not be subject to backup withholding on payments you receive if you give the requester your correct TIN, make the proper certifications, and report all your taxable interest and dividends on your tax return.

Payments you receive will be subject to backup withholding if:

1. You do not furnish your TIN to the requester,
2. You do not certify your TIN when required (see the instructions for Part II for details),
3. The IRS tells the requester that you furnished an incorrect TIN,
4. The IRS tells you that you are subject to backup withholding because you did not report all your interest and dividends on your tax return (for reportable interest and dividends only), or
5. You do not certify to the requester that you are not subject to backup withholding under 4 above (for reportable interest and dividend accounts opened after 1983 only).

Certain payees and payments are exempt from backup withholding. See *Exempt payee code*, later, and the separate Instructions for the Requester of Form W-9 for more information.

Also see *Special rules for partnerships*, earlier.

What is FATCA Reporting?

The Foreign Account Tax Compliance Act (FATCA) requires a participating foreign financial institution to report all United States account holders that are specified United States persons. Certain payees are exempt from FATCA reporting. See *Exemption from FATCA reporting code*, later, and the Instructions for the Requester of Form W-9 for more information.

Updating Your Information

You must provide updated information to any person to whom you claimed to be an exempt payee if you are no longer an exempt payee and anticipate receiving reportable payments in the future from this person. For example, you may need to provide updated information if you are a C corporation that elects to be an S corporation, or if you no longer are tax exempt. In addition, you must furnish a new Form W-9 if the name or TIN changes for the account; for example, if the grantor of a grantor trust dies.

Penalties

Failure to furnish TIN. If you fail to furnish your correct TIN to a requester, you are subject to a penalty of \$50 for each such failure unless your failure is due to reasonable cause and not to willful neglect.

Civil penalty for false information with respect to withholding. If you make a false statement with no reasonable basis that results in no backup withholding, you are subject to a \$500 penalty.

Criminal penalty for falsifying information. Willfully falsifying certifications or affirmations may subject you to criminal penalties including fines and/or imprisonment.

Misuse of TINs. If the requester discloses or uses TINs in violation of federal law, the requester may be subject to civil and criminal penalties.

Specific Instructions

Line 1

You must enter one of the following on this line; **do not** leave this line blank. The name should match the name on your tax return.

If this Form W-9 is for a joint account (other than an account maintained by a foreign financial institution (FFI)), list first, and then circle, the name of the person or entity whose number you entered in Part I of Form W-9. If you are providing Form W-9 to an FFI to document a joint account, each holder of the account that is a U.S. person must provide a Form W-9.

a. **Individual.** Generally, enter the name shown on your tax return. If you have changed your last name without informing the Social Security Administration (SSA) of the name change, enter your first name, the last name as shown on your social security card, and your new last name.

Note: ITIN applicant: Enter your individual name as it was entered on your Form W-7 application, line 1a. This should also be the same as the name you entered on the Form 1040/1040A/1040EZ you filed with your application.

b. **Sole proprietor or single-member LLC.** Enter your individual name as shown on your 1040/1040A/1040EZ on line 1. You may enter your business, trade, or "doing business as" (DBA) name on line 2.

c. **Partnership, LLC that is not a single-member LLC, C corporation, or S corporation.** Enter the entity's name as shown on the entity's tax return on line 1 and any business, trade, or DBA name on line 2.

d. **Other entities.** Enter your name as shown on required U.S. federal tax documents on line 1. This name should match the name shown on the charter or other legal document creating the entity. You may enter any business, trade, or DBA name on line 2.

e. **Disregarded entity.** For U.S. federal tax purposes, an entity that is disregarded as an entity separate from its owner is treated as a "disregarded entity." See Regulations section 301.7701-2(c)(2)(iii). Enter the owner's name on line 1. The name of the entity entered on line 1 should never be a disregarded entity. The name on line 1 should be the name shown on the income tax return on which the income should be reported. For example, if a foreign LLC that is treated as a disregarded entity for U.S. federal tax purposes has a single owner that is a U.S. person, the U.S. owner's name is required to be provided on line 1. If the direct owner of the entity is also a disregarded entity, enter the first owner that is not disregarded for federal tax purposes. Enter the disregarded entity's name on line 2, "Business name/disregarded entity name." If the owner of the disregarded entity is a foreign person, the owner must complete an appropriate Form W-8 instead of a Form W-9. This is the case even if the foreign person has a U.S. TIN.

Line 2

If you have a business name, trade name, DBA name, or disregarded entity name, you may enter it on line 2.

Line 3

Check the appropriate box on line 3 for the U.S. federal tax classification of the person whose name is entered on line 1. Check only one box on line 3.

IF the entity/person on line 1 is a(n) . . .	THEN check the box for . . .
• Corporation	Corporation
• Individual • Sole proprietorship, or • Single-member limited liability company (LLC) owned by an individual and disregarded for U.S. federal tax purposes.	Individual/sole proprietor or single-member LLC
• LLC treated as a partnership for U.S. federal tax purposes, • LLC that has filed Form 8832 or 2553 to be taxed as a corporation, or • LLC that is disregarded as an entity separate from its owner but the owner is another LLC that is not disregarded for U.S. federal tax purposes.	Limited liability company and enter the appropriate tax classification. (P= Partnership; C= C corporation; or S= S corporation)
• Partnership	Partnership
• Trust/estate	Trust/estate

Line 4, Exemptions

If you are exempt from backup withholding and/or FATCA reporting, enter in the appropriate space on line 4 any code(s) that may apply to you.

Exempt payee code.

- Generally, individuals (including sole proprietors) are not exempt from backup withholding.
- Except as provided below, corporations are exempt from backup withholding for certain payments, including interest and dividends.
- Corporations are not exempt from backup withholding for payments made in settlement of payment card or third party network transactions.
- Corporations are not exempt from backup withholding with respect to attorneys' fees or gross proceeds paid to attorneys, and corporations that provide medical or health care services are not exempt with respect to payments reportable on Form 1099-MISC.

The following codes identify payees that are exempt from backup withholding. Enter the appropriate code in the space in line 4.

- 1—An organization exempt from tax under section 501(a), any IRA, or a custodial account under section 403(b)(7) if the account satisfies the requirements of section 401(f)(2)
- 2—The United States or any of its agencies or instrumentalities
- 3—A state, the District of Columbia, a U.S. commonwealth or possession, or any of their political subdivisions or instrumentalities
- 4—A foreign government or any of its political subdivisions, agencies, or instrumentalities
- 5—A corporation
- 6—A dealer in securities or commodities required to register in the United States, the District of Columbia, or a U.S. commonwealth or possession
- 7—A futures commission merchant registered with the Commodity Futures Trading Commission
- 8—A real estate investment trust
- 9—An entity registered at all times during the tax year under the Investment Company Act of 1940
- 10—A common trust fund operated by a bank under section 584(a)
- 11—A financial institution
- 12—A middleman known in the investment community as a nominee or custodian
- 13—A trust exempt from tax under section 664 or described in section 4947

The following chart shows types of payments that may be exempt from backup withholding. The chart applies to the exempt payees listed above, 1 through 13.

IF the payment is for . . .	THEN the payment is exempt for . . .
Interest and dividend payments	All exempt payees except for 7
Broker transactions	Exempt payees 1 through 4 and 6 through 11 and all C corporations. S corporations must not enter an exempt payee code because they are exempt only for sales of noncovered securities acquired prior to 2012.
Barter exchange transactions and patronage dividends	Exempt payees 1 through 4
Payments over \$600 required to be reported and direct sales over \$5,000 ¹	Generally, exempt payees 1 through 5 ²
Payments made in settlement of payment card or third party network transactions	Exempt payees 1 through 4

¹ See Form 1099-MISC, Miscellaneous Income, and its instructions.

² However, the following payments made to a corporation and reportable on Form 1099-MISC are not exempt from backup withholding: medical and health care payments, attorneys' fees, gross proceeds paid to an attorney reportable under section 6045(f), and payments for services paid by a federal executive agency.

Exemption from FATCA reporting code. The following codes identify payees that are exempt from reporting under FATCA. These codes apply to persons submitting this form for accounts maintained outside of the United States by certain foreign financial institutions. Therefore, if you are only submitting this form for an account you hold in the United States, you may leave this field blank. Consult with the person requesting this form if you are uncertain if the financial institution is subject to these requirements. A requester may indicate that a code is not required by providing you with a Form W-9 with "Not Applicable" (or any similar indication) written or printed on the line for a FATCA exemption code.

A—An organization exempt from tax under section 501(a) or any individual retirement plan as defined in section 7701(a)(37)

B—The United States or any of its agencies or instrumentalities

C—A state, the District of Columbia, a U.S. commonwealth or possession, or any of their political subdivisions or instrumentalities

D—A corporation the stock of which is regularly traded on one or more established securities markets, as described in Regulations section 1.1472-1(c)(1)(i)

E—A corporation that is a member of the same expanded affiliated group as a corporation described in Regulations section 1.1472-1(c)(1)(i)

F—A dealer in securities, commodities, or derivative financial instruments (including notional principal contracts, futures, forwards, and options) that is registered as such under the laws of the United States or any state

G—A real estate investment trust

H—A regulated investment company as defined in section 851 or an entity registered at all times during the tax year under the Investment Company Act of 1940

I—A common trust fund as defined in section 584(a)

J—A bank as defined in section 581

K—A broker

L—A trust exempt from tax under section 664 or described in section 4947(a)(1)

M—A tax exempt trust under a section 403(b) plan or section 457(g) plan

Note: You may wish to consult with the financial institution requesting this form to determine whether the FATCA code and/or exempt payee code should be completed.

Line 5

Enter your address (number, street, and apartment or suite number). This is where the requester of this Form W-9 will mail your information returns. If this address differs from the one the requester already has on file, write NEW at the top. If a new address is provided, there is still a chance the old address will be used until the payor changes your address in their records.

Line 6

Enter your city, state, and ZIP code.

Part I. Taxpayer Identification Number (TIN)

Enter your TIN in the appropriate box. If you are a resident alien and you do not have and are not eligible to get an SSN, your TIN is your IRS individual taxpayer identification number (ITIN). Enter it in the social security number box. If you do not have an ITIN, see *How to get a TIN* below.

If you are a sole proprietor and you have an EIN, you may enter either your SSN or EIN.

If you are a single-member LLC that is disregarded as an entity separate from its owner, enter the owner's SSN (or EIN, if the owner has one). Do not enter the disregarded entity's EIN. If the LLC is classified as a corporation or partnership, enter the entity's EIN.

Note: See *What Name and Number To Give the Requester*, later, for further clarification of name and TIN combinations.

How to get a TIN. If you do not have a TIN, apply for one immediately. To apply for an SSN, get Form SS-5, Application for a Social Security Card, from your local SSA office or get this form online at www.SSA.gov. You may also get this form by calling 1-800-772-1213. Use Form W-7, Application for IRS Individual Taxpayer Identification Number, to apply for an ITIN, or Form SS-4, Application for Employer Identification Number, to apply for an EIN. You can apply for an EIN online by accessing the IRS website at www.irs.gov/Businesses and clicking on Employer Identification Number (EIN) under Starting a Business. Go to www.irs.gov/Forms to view, download, or print Form W-7 and/or Form SS-4. Or, you can go to www.irs.gov/OrderForms to place an order and have Form W-7 and/or SS-4 mailed to you within 10 business days.

If you are asked to complete Form W-9 but do not have a TIN, apply for a TIN and write "Applied For" in the space for the TIN, sign and date the form, and give it to the requester. For interest and dividend payments, and certain payments made with respect to readily tradable instruments, generally you will have 60 days to get a TIN and give it to the requester before you are subject to backup withholding on payments. The 60-day rule does not apply to other types of payments. You will be subject to backup withholding on all such payments until you provide your TIN to the requester.

Note: Entering "Applied For" means that you have already applied for a TIN or that you intend to apply for one soon.

Caution: A disregarded U.S. entity that has a foreign owner must use the appropriate Form W-8.

Part II. Certification

To establish to the withholding agent that you are a U.S. person, or resident alien, sign Form W-9. You may be requested to sign by the withholding agent even if item 1, 4, or 5 below indicates otherwise.

For a joint account, only the person whose TIN is shown in Part I should sign (when required). In the case of a disregarded entity, the person identified on line 1 must sign. Exempt payees, see *Exempt payee code*, earlier.

Signature requirements. Complete the certification as indicated in items 1 through 5 below.

1. Interest, dividend, and barter exchange accounts opened before 1984 and broker accounts considered active during 1983.

You must give your correct TIN, but you do not have to sign the certification.

2. Interest, dividend, broker, and barter exchange accounts opened after 1983 and broker accounts considered inactive during 1983.

You must sign the certification or backup withholding will apply. If you are subject to backup withholding and you are merely providing your correct TIN to the requester, you must cross out item 2 in the certification before signing the form.

3. Real estate transactions. You must sign the certification. You may cross out item 2 of the certification.

4. Other payments. You must give your correct TIN, but you do not have to sign the certification unless you have been notified that you have previously given an incorrect TIN. "Other payments" include payments made in the course of the requester's trade or business for rents, royalties, goods (other than bills for merchandise), medical and health care services (including payments to corporations), payments to a nonemployee for services, payments made in settlement of payment card and third party network transactions, payments to certain fishing boat crew members and fishermen, and gross proceeds paid to attorneys (including payments to corporations).

5. Mortgage interest paid by you, acquisition or abandonment of secured property, cancellation of debt, qualified tuition program payments (under section 529), ABLE accounts (under section 529A), IRA, Coverdell ESA, Archer MSA or HSA contributions or distributions, and pension distributions. You must give your correct TIN, but you do not have to sign the certification.

What Name and Number To Give the Requester

For this type of account:	Give name and SSN of:
1. Individual	The individual
2. Two or more individuals (joint account) other than an account maintained by an FFI	The actual owner of the account or, if combined funds, the first individual on the account ¹
3. Two or more U.S. persons (joint account maintained by an FFI)	Each holder of the account
4. Custodial account of a minor (Uniform Gift to Minors Act)	The minor ²
5. a. The usual revocable savings trust (grantor is also trustee)	The grantor-trustee ¹
b. So-called trust account that is not a legal or valid trust under state law	The actual owner ¹
6. Sole proprietorship or disregarded entity owned by an individual	The owner ³
7. Grantor trust filing under Optional Form 1099 Filing Method 1 (see Regulations section 1.671-4(b)(2)(i)(A))	The grantor*
For this type of account:	Give name and EIN of:
8. Disregarded entity not owned by an individual	The owner
9. A valid trust, estate, or pension trust	Legal entity ⁴
10. Corporation or LLC electing corporate status on Form 8832 or Form 2553	The corporation
11. Association, club, religious, charitable, educational, or other tax-exempt organization	The organization
12. Partnership or multi-member LLC	The partnership
13. A broker or registered nominee	The broker or nominee

For this type of account:	Give name and EIN of:
14. Account with the Department of Agriculture in the name of a public entity (such as a state or local government, school district, or prison) that receives agricultural program payments	The public entity
15. Grantor trust filing under the Form 1041 Filing Method or the Optional Form 1099 Filing Method 2 (see Regulations section 1.671-4(b)(2)(i)(B))	The trust

¹ List first and circle the name of the person whose number you furnish. If only one person on a joint account has an SSN, that person's number must be furnished.

² Circle the minor's name and furnish the minor's SSN.

³ You must show your individual name and you may also enter your business or DBA name on the "Business name/disregarded entity" name line. You may use either your SSN or EIN (if you have one), but the IRS encourages you to use your SSN.

⁴ List first and circle the name of the trust, estate, or pension trust. (Do not furnish the TIN of the personal representative or trustee unless the legal entity itself is not designated in the account title.) Also see *Special rules for partnerships*, earlier.

*Note: The grantor also must provide a Form W-9 to trustee of trust.

Note: If no name is circled when more than one name is listed, the number will be considered to be that of the first name listed.

Secure Your Tax Records From Identity Theft

Identity theft occurs when someone uses your personal information such as your name, SSN, or other identifying information, without your permission, to commit fraud or other crimes. An identity thief may use your SSN to get a job or may file a tax return using your SSN to receive a refund.

To reduce your risk:

- Protect your SSN,
- Ensure your employer is protecting your SSN, and
- Be careful when choosing a tax preparer.

If your tax records are affected by identity theft and you receive a notice from the IRS, respond right away to the name and phone number printed on the IRS notice or letter.

If your tax records are not currently affected by identity theft but you think you are at risk due to a lost or stolen purse or wallet, questionable credit card activity or credit report, contact the IRS Identity Theft Hotline at 1-800-908-4490 or submit Form 14039.

For more information, see Pub. 5027, Identity Theft Information for Taxpayers.

Victims of identity theft who are experiencing economic harm or a systemic problem, or are seeking help in resolving tax problems that have not been resolved through normal channels, may be eligible for Taxpayer Advocate Service (TAS) assistance. You can reach TAS by calling the TAS toll-free case intake line at 1-877-777-4778 or TTY/TDD 1-800-829-4059.

Protect yourself from suspicious emails or phishing schemes.

Phishing is the creation and use of email and websites designed to mimic legitimate business emails and websites. The most common act is sending an email to a user falsely claiming to be an established legitimate enterprise in an attempt to scam the user into surrendering private information that will be used for identity theft.

The IRS does not initiate contacts with taxpayers via emails. Also, the IRS does not request personal detailed information through email or ask taxpayers for the PIN numbers, passwords, or similar secret access information for their credit card, bank, or other financial accounts.

If you receive an unsolicited email claiming to be from the IRS, forward this message to phishing@irs.gov. You may also report misuse of the IRS name, logo, or other IRS property to the Treasury Inspector General for Tax Administration (TIGTA) at 1-800-366-4484. You can forward suspicious emails to the Federal Trade Commission at spam@uce.gov or report them at www.ftc.gov/complaint. You can contact the FTC at www.ftc.gov/idtheft or 877-IDTHEFT (877-438-4338). If you have been the victim of identity theft, see www.IdentityTheft.gov and Pub. 5027.

Visit www.irs.gov/IdentityTheft to learn more about identity theft and how to reduce your risk.

Privacy Act Notice

Section 6109 of the Internal Revenue Code requires you to provide your correct TIN to persons (including federal agencies) who are required to file information returns with the IRS to report interest, dividends, or certain other income paid to you; mortgage interest you paid; the acquisition or abandonment of secured property; the cancellation of debt; or contributions you made to an IRA, Archer MSA, or HSA. The person collecting this form uses the information on the form to file information returns with the IRS, reporting the above information. Routine uses of this information include giving it to the Department of Justice for civil and criminal litigation and to cities, states, the District of Columbia, and U.S. commonwealths and possessions for use in administering their laws. The information also may be disclosed to other countries under a treaty, to federal and state agencies to enforce civil and criminal laws, or to federal law enforcement and intelligence agencies to combat terrorism. You must provide your TIN whether or not you are required to file a tax return. Under section 3406, payers must generally withhold a percentage of taxable interest, dividend, and certain other payments to a payee who does not give a TIN to the payer. Certain penalties may also apply for providing false or fraudulent information.

Contractor Qualifications

Please attach appropriate contractor qualifications which includes:

1. **QUALIFICATIONS & REFERENCES:** Please attach appropriate qualifications here including project descriptions and reference contact information for not less than three (3) similar natural surface trail construction projects that include similar specifications and amount of trail constructed to those outlined in this project.
2. **PROJECT APPROACH:** Include proposed construction schedule and approach for each component project, including machines/materials to be utilized, identification and experience of on-site personnel on similar projects with similar machines/materials

TRAIL MAINTENANCE AND ENHANCEMENTS AT THE BAILEYS TRAIL SYSTEM
REQUEST FOR QUOTES
ATHENS-WAYNE OUTDOOR ASSET DEVELOPMENT CORPORATION

IV. PROJECT SPECIFICATIONS

Division 1 - General Requirements

Section 1.1 PROJECT LOCATION

The work is located on land owned by the United States Department of Agriculture - Wayne National Forest. This project is located on the Athens Unit of the Athens Ranger District of the Wayne National Forest. The trail system is managed by the Outdoor Recreation Council of Appalachia (ORCA). The Athens-Wayne Outdoor Asset Development Corporation (AWOADC) is the nonprofit partner of the Outdoor Recreation Council of Appalachia (ORCA).

Section 1.2 DESCRIPTION OF WORK

This project is for trail construction services related to the *TRAIL MAINTENANCE & ENHANCEMENTS AT THE BAILEYS TRAIL SYSTEM*, including the following:

1. Widen natural surface trail tread on 5.35 miles of trail to accommodate adaptive mountain bikes
 - a. Trails were constructed as Frontcountry Natural Surface Trails with a tread width of 36" – 50". After a few years of use, erosion and drainage has caused certain locations to decrease width below 36". This portion of the project requires reviewing the entire length of each trail and widening any section that does not meet that minimum specification for adaptive mountain bikes.
 - b. Two culverts should be widened to address particular sections experiencing erosion. Culverts will be 36-48" wide and 12-16' in length.
2. Address drainage and erosion concerns on the same 5.35 miles of trails to ensure adaptive mountain bike standards are met and improve first-time trail user experiences.
 - a. Address high-priority drainage issues on each trail with heavy maintenance, regrading, and rock armoring as needed.
 - b. Rock armoring should be utilized as needed. Natural rock can be used where available, and imported rock should be used as needed. Owner is likely able to provide imported rock if needed.
3. Involving Volunteers in trail maintenance projects is a goal of this project. Contractors will coordinate with the Owner's Representative and the AWOADC to set aside an appropriate section of work for volunteers to address.

TRAIL MAINTENANCE AND ENHANCEMENTS AT THE BAILEYS TRAIL SYSTEM
REQUEST FOR QUOTES
ATHENS-WAYNE OUTDOOR ASSET DEVELOPMENT CORPORATION

4. Furnish all labor, materials, equipment, tools, supplies, supervision, transportation, and all incidentals necessary to perform all of the work required as shown in the Specifications and in acceptable conformity with the lines, grades, design, and dimensions shown in the project site plans.
5. Final design, construction, and restoration, including all required tread materials, in accordance with the Specifications found in Attachment C. Adaptive Mountain Bike Trail Specifications for a-mtb blue/intermediate trail where existing backslopes are less than 3' in height and to a-mtb black/difficult where existing backslopes are greater than 3' in height.

Rock armor and culvert placement shall meet the specifications outlined in the Baileys Trail Construction Documents. Surfacing material should include fines and be applied to a depth of 6" and compacted

6. This work shall be completed in a safe and conscientious manner and in accordance with DIVISION 4 - CONSTRUCTION SCOPES & SPECIFICATIONS, Attachment A. Baileys Construction Documents, Attachment B. Frontcountry Natural Surface Trail Specifications, Attachment C. Adaptive Mountain Bike Trail Specifications, Attachment D. Clean Air and Federal Water Pollution Control Act, and Attachment E. Maps.

Section 1.3 Materials

Materials as used in these specifications shall mean equipment, machinery, product, component or any other item to be incorporated in the work. Before performing any work or ordering any materials, the Contractor shall verify all dimensions of any existing and new work and shall be responsible for their accuracy.

Materials furnished by the Contractor shall be of the type and quality described in these specifications. Substitute materials may be used, provided no substitute materials shall be used without prior written approval by the Owner's Representative and Wayne National Forest. The Owner's Representative determination as to whether substitution will be permitted will be final and conclusive.

Cost of delays because of non-availability of specified items when such delays could have been avoided by the Contractor, shall not be borne by the ORCA.

Section 1.4 Access and Haul Routes

The Contractor shall make his own investigation of the condition of available public or private roads to determine clearances, restrictions, and other limitations that affect transportation at the job site.

TRAIL MAINTENANCE AND ENHANCEMENTS AT THE BAILEYS TRAIL SYSTEM
REQUEST FOR QUOTES
ATHENS-WAYNE OUTDOOR ASSET DEVELOPMENT CORPORATION

Existing roads are available for the Contractor's use provided they are inside the project boundary. The Contractor will repair any damage on existing roads caused by the Contractor. The hauling of sand, gravel, earth materials, concrete, or other hauling, shall be in compliance with applicable local regulations and shall minimize interference with local traffic.

Where haul routes cross public roads or highways, the Contractor shall provide barricades, flag people, and other necessary precautions for the safety of the public. The Contractor will take all necessary precautions so as not to unnecessarily restrict traffic flow on Forest Roads and entering nearby roads and highways.

Section 1.5 Power and Water

The Contractor shall make all necessary arrangements and shall provide all power and water required for construction purposes. At the termination of this contract, the Contractor shall dismantle and remove all distribution lines used for construction that are not part of the permanent installation. Contractor will call for existing utility locations as is necessary.

Section 1.6 Staging Area

Staging areas for on-site storage of equipment, materials, or other items that are needed for construction will be approved by the Owner's Representative and Wayne National Forest before construction of this contract begins.

Section 1.7 Preservation of Vegetation

The Contractor shall exercise care to preserve the natural landscape, including trees and shrubs, and shall conduct construction operations so as to prevent any unnecessary destruction, scarring, or defacing of the natural surroundings in the vicinity of the work. Except where clearing is required for permanent works or excavation operations, all trees, native shrubbery, and vegetation, shall be preserved and protected from damage by the Contractor's construction operations and equipment.

All unnecessary destruction, scarring, damage or defacing of the landscape resulting from the Contractor's operations, shall be repaired, replanted, reseeded or otherwise corrected as directed by the Owner's Representative and at the Contractor's expense.

After completion of the work, all areas disturbed by construction that do not require landscaping or planting, shall be scarified and left in a condition which will facilitate natural vegetation, provide for proper drainage and prevent erosion.

Section 1.8 Clean-Up

TRAIL MAINTENANCE AND ENHANCEMENTS AT THE BAILEYS TRAIL SYSTEM
REQUEST FOR QUOTES
ATHENS-WAYNE OUTDOOR ASSET DEVELOPMENT CORPORATION

Due to the public nature of the sites, clean-up during construction is extremely important. General clean-up will be carried out by the Contractor over the limits of the entire project to the satisfaction of the Owner's Representative. This includes touch-up work, patching, and clean-up of all materials related to this contract and Contractor. Clean-up will not be paid for separately but will be included in the prices bid in the schedule.

Any vandalism is the responsibility of the contractor until the project is accepted by the ORCA. Contractor will place signage at access points and adjacent to the project site during and throughout construction.

Section 1.9 NEPA Compliance & Forest Service Coordination

The following action items shall be taken by means of coordinating with Forest Service Personnel to ensure compliance with the National Environmental Protection Act (NEPA):

- A. Forest Service personnel will attend the pre-construction meeting to review specifications and mitigations as identified in the NEPA analysis and survey outcomes.
- B. Forest Service personnel will field verify (on-the-ground) trail corridors prior to construction.
 - a. Trail center lines are marked to a standard that line of sight between markers is present.
 - b. Trail corridor construction widths are identified and communicated to contractors prior to the start of each week of construction.
 - c. Regular (no less than at least once per week) un-scheduled inspections are conducted.
- C. Forest Service personnel will ensure contractors cease construction if deviations from the approved corridor are expected.
- D. If construction occurs outside the approved corridor, the contractor will be in breach of the contract and the contract will be terminated.
- E. If the contractor sees a need to deviate from the approved/surveyed corridor, work must cease, and coordination must occur with the Forest Service. Additional surveys may be required. Not all re-routes will be possible based on protection needs for other resources.
 - a. Needs for additional surveys cannot always be accommodated in a timely manner, so requests to re-route the trail corridor should be limited.

Section 1.10 Guarantee and Warranty

TRAIL MAINTENANCE AND ENHANCEMENTS AT THE BAILEYS TRAIL SYSTEM
REQUEST FOR QUOTES
ATHENS-WAYNE OUTDOOR ASSET DEVELOPMENT CORPORATION

A one (1) year guarantee and warranty will be provided by the Contractor on all work of this project. Any portions needing replacement or repair within one (1) YEAR FROM THE DATE OF WRITTEN ACCEPTANCE by the ORCA shall be completed by the Contractor at his expense, within a time frame agreed upon by ORCA. All manufacturer warranties shall be transferred to ORCA.

Division 2 - Earthwork

Section 2.1 General

All costs for earthwork of this project; excavation, stripping and backfilling, are considered subsidiary to the installation of natural surface trail and associated costs are to be included with the associated bid items, not to be paid separately. Bidders and the Contractor shall assume all responsibility for deductions and conclusions as to the nature of the materials to be excavated and the difficulties of making and maintaining the required excavations. Excavation shall be made to the lines, grades and dimensions 30 prescribed in the various paragraphs of these specifications and as shown on the drawings. No excavation shall be made in frozen materials without written approval from the Owner's Representative.

All necessary precautions shall be taken to preserve the material below and beyond the established lines of all excavation. Any damage to the work due to the Contractor's operations shall be repaired at the expense of and by the Contractor. Material beyond the required or prescribed excavation lines which is loosened or disturbed by the Contractor's operations shall be removed or fine graded at the expense of the Contractor.

Where additional excavation is prescribed by the Owner's Representative to remove unsuitable foundation material, all earthwork due to such additional excavation shall be in accordance with these specifications.

The trail surfaces to be constructed shall be finished to the dimensions shown on the drawings or prescribed by the Owner's Representative. The surfaces shall be tamped or rolled with suitable tools or equipment to form a compacted trail tread.

Section 2.2 Excavation For Drainage

The Contractor shall perform excavation for the drainage, and as may be instructed by the Owner's Representative.

The drainage channels shall have side slopes and bottom widths to conform to the topographic and hydraulic conditions to be met.

Section 2.3 Backfill

All backfill shall be placed moistened and compacted to the trail surface. The material to be compacted shall be deposited in approximately horizontal layers which shall not be more than 6 inches in thickness and the layers shall be moistened.

Backfill material shall be obtained from material moved in required excavations or within 25' of the established tread centerline. Backfill shall be placed to the lines and grades shown in the drawings for the purpose of a sustainable, natural surface trail, or as required by the Owner's Representative.

Division 3 - Completion Requirements

Section 3.1 Payment

Payment shall be for each project completed and in place as per the bid schedule, for which price and payment shall be full compensation for all materials, labor, installation, transportation, and any other incidentals necessary to complete the project according to the specifications and drawings. Payment will be based on a monthly total of work completed, trail completion will be measured by rolling wheel by the Owner's Representative in the presence of Contractor. Payment will be provided within 30 days of complete invoice approval and provision of applicable prevailing wage reports.

The amount of funds available on this project is a set amount and cannot be overrun. If the total amount exceeds the monies available, the scope of the contract will be reduced to an amount of the bid necessary to commensurate to funding available. Should the amount decreased exceed twenty-five percent (25%) of the total bid, new unit prices can be negotiated by ORCA and the lowest responsible bidder.

Said work shall commence following the Notice to Proceed and will be completed by **May 1, 2025**. Concept of the work is to start and to progress without interruption until the job is complete. Bidders shall understand that if circumstances arise that a contract extension is needed, one shall be granted due to inclement weather, acts of God, and acts beyond the control of the Contractor, such as strikes, fire, lockouts, and unusual delays in shipment. Time extensions shall be requested in writing within two weeks of the occurrence. The Owner's Representative and the Contractor shall mutually agree on a reasonable extension of time.

In the event that all work is not completed by **May 1, 2025** the ORCA will assess three hundred dollars (\$300.00) per working day, not as a penalty, but as liquidated damages to the ORCA. The liquidated damages assessment for non-completion by the time specified will be computed beginning the day following the first working day specified for completion and continuing each

TRAIL MAINTENANCE AND ENHANCEMENTS AT THE BAILEYS TRAIL SYSTEM
REQUEST FOR QUOTES
ATHENS-WAYNE OUTDOOR ASSET DEVELOPMENT CORPORATION

and every working day until all items shown on the proposal are completed. If it is necessary to apply this assessment, the total amount of such damages will be deducted from the final voucher drawn in payment for the contract.

Section 3.2 General Comments

Workmanship shall be of the best quality. The professional appearance of finished work shall be of equal importance with its intended use. All portions of the work shall be so laid out and installed so that the work, as a whole, is of uniform quality and appearance.

A pre-construction conference shall be scheduled by the Contractor and ORCA to take place not more than one week prior to commencing construction. The meeting shall include the ORCA, Wayne National Forest, the Owner's Representative, and appropriate representatives of the Contractor who will be responsible for the management of the project. Major subcontractors shall also attend. Conference establishes a time to discuss the nature and location of the work and the general and local conditions of the site by visiting the site and becoming thoroughly familiar with the sites.

Division 4 - Construction Specifications

Project Specifications

- USFS Hiker Trail- Class 3
- Trail Corridor: 5' wide by 8' high
- Front Country Natural Surface Trails 36" - 50" Tread Width
- Surfacing: Native with some onsite borrow where needed for stabilization
- Rock Armor: Flagstone armor with 1'-wide or larger stone
- **See Attachment A. Baileys Construction Documents**
- **See Attachment B. Frontcountry Natural Surface Trail Specifications**
- **See Attachment C. Adaptive Mountain Bike Trail Specifications**
- **See Attachment D. Clean Air and Federal Water Pollution Control Act**
- **See Attachment E. Maps**

Project Notes

The work involves widening previously constructed trails (Gob Pile, Coal Train, and Bullfrog) to meet a-mtb standards. The existing tread is generally full bench cut and 40 – 48" in width between critical points. The goal is to meet the a-mtb standard for intermediate level trails with a

TRAIL MAINTENANCE AND ENHANCEMENTS AT THE BAILEYS TRAIL SYSTEM
REQUEST FOR QUOTES
ATHENS-WAYNE OUTDOOR ASSET DEVELOPMENT CORPORATION

60” tread width. Where steep slopes were constructed upon and backslopes are greater than 3’ in height, the tread reconstruction to reach the 60” width is not practical. In these locations, a 48” tread width will suffice.

Manipulation of the existing tread, along with minor excavation to reach the desired width should leave the reconstructed tread with a slightly outsloped surface to the greatest extent practical. Where tread reconstruction should be slightly insloped to maintain a-mtb lateral stability, a return to a slightly outsloped condition should be constructed immediately before and after the insloped section.

Where trees need to be removed (only remove specimens less than 6” dbh unless approved by client representative) to achieve the specified width, it is preferable to remove upslope trees to keep the trail anchored by downslope trees.

In many locations on these trails, there have been persistent drainage challenges that have resulted in mud holes or excessively wet tread. Where broad-based dips (10-15’ long drainage face/knick) are specified, the final outslope should be 3-5% to maximize stability for a-mtb use. To achieve this, it is anticipated that some trail adjacent excavation and subsequent naturalization will be necessary.

Rock armor locations were confirmed to have surface rock adjacent to the work area or within approximately 250’ down the trail.

Culverts are to be replaced with 8’ sections of hdpe double walled culverts, cut in half lengthwise to provide an open bottom and the managed tread over the top of the culvert should be 84” with 6” of rock facing on each end.

TRAIL MAINTENANCE AND ENHANCEMENTS AT THE BAILEYS TRAIL SYSTEM
REQUEST FOR QUOTES
ATHENS-WAYNE OUTDOOR ASSET DEVELOPMENT CORPORATION

V. GENERAL PROVISIONS

ARTICLE 1 - CONTRACT AND CONTRACT DOCUMENTS

A. The project to be constructed pursuant to this contract will be financed with assistance from the Appalachian Regional Commission and is subject to all applicable Federal laws and regulations.

B. All applicable State laws, municipal ordinances, and the rules and regulations of all authorities having jurisdiction over construction of the project shall apply to the contract throughout, and they will be deemed to be included in the contract the same as though herein written out in full.

C. The Scope, Specifications and Addenda shall form part of this Contract and provisions thereof shall be as binding upon the parties hereto as if they were herein fully set forth. The table of contents, titles, headings, running headlines and marginal notes contained herein and in said documents are solely to facilitate reference to various provisions of the Contract Documents and in no way affect, limit or cast light on the interpretation of the provisions to which they refer.

ARTICLE 2 - WAGE RATES

In the event that the rate of wages paid for any trade or occupant in the locality where such work is being performed are under current collective agreements or understandings between bona fide organizations of labor and employer, then the wages to be paid shall be not less than such agreed wage rates, nor less than the minimum rates compiled by the Federal Labor Standard Provision. A copy of these prevailing rates of wages has been included in these specifications.

Every Contractor and Subcontractor who is subject to this contract shall, as soon as he/she begins performance under his/her contract with the Owner, supply the Owner a schedule of dates on which he/she is required to pay wages to employees. He/She shall also deliver to the prevailing wage coordinator within three weeks after each pay date, a certified copy of his/her payroll which shall exhibit for each employee paid any wages, name, current address, social security number, number of hours worked each day of the pay period and total for each week, hourly rate of pay, job classification, fringe payments, and deductions from wages. The certification of each payroll shall be executed by the Contractor, Subcontractor, or duly executed by the Contractor, Subcontractor, or duly appointed agent thereof and shall recite that the payroll is correct and complete and that the wage rate shown is not less than those required by the contract. Insofar as possible, **local labor shall be employed on this work.**

ARTICLE 3 - AFFIRMATIVE ACTION

Each bidder, Contractor, and/or Subcontractor, must fully comply with either Part 1 or Part 11, as applicable, of Executive Order 1246 as stated during the performance of this contract or subcontract. The Contractor commits itself to the goals for minority manpower utilization in either Part 1 or Part 11, as applicable, and all other requirements, terms and conditions of those proposal conditions by submitting a properly signed bid.

The Contractor shall appoint a company executive to assume the responsibility for the implementation of the requirements, terms and conditions of these bid conditions.

ARTICLE 4 - INSURANCE

- A. The Contractor shall not commence work under this Contract until he has obtained all the insurance required hereunder and such insurance has been approved by the Owner, nor shall the Contractor allow any Subcontractor to commence work on his subcontract until all similar insurance required of the Subcontractor has been so obtained and approved. Approval of the insurance by the Owner shall not relieve or decrease the liability of the Contractor hereunder.

- B. The Contractor shall file with the Owner all Certificate(s) of Insurance as are necessary to document the insurance coverage required hereunder, subject to the approval of the Owner and receipt of any additional forms/documentation requested, prior to final execution of the Agreement Contract and issuance of the Notice to Proceed.

- C. Worker's Compensation
 - a) All contractors and subcontractors shall acquire and maintain, during the term of the Contract, Worker's Compensation insurance in full compliance with the laws of the State of Ohio.

- D. Contractor's Liability Insurance
 - a) The Contractor shall acquire and maintain during the term of the Contract Bodily Injury and Property Damage Liability Insurance under a standard Comprehensive General/Automobile Liability Policy which shall provide and include coverage on all Contractor's Operations, Contractor's Protective (Sublet) Liability, Contractual Liability, Completed Operations Liability, Owned Automobiles and Non-owned and Hired Automobiles.

TRAIL MAINTENANCE AND ENHANCEMENTS AT THE BAILEYS TRAIL SYSTEM
REQUEST FOR QUOTES
ATHENS-WAYNE OUTDOOR ASSET DEVELOPMENT CORPORATION

- b) Property Damage Liability Insurance shall be provided on any demolition, blasting, excavating, shoring or similar operation on an "if any" basis.
- c) Bodily Injury Liability limits shall be for an amount of no less than Two Hundred Fifty Thousand (\$250,000) Dollars for injuries, including wrongful death to any one person and subject to the same limit for each person, in an amount of not less than Five Hundred Thousand (\$500,000) Dollars on the account of any one occurrence.
- d) Property Damage Liability insurance shall be in an amount of not less than One Hundred Thousand (\$100,000) per occurrence. General Liability shall be extended to provide "Broad Form Property Damage Liability," and in an amount of not less than One Million (\$1,000,000) Dollars aggregate for damage on account of all occurrences.
- e) Any combination of underlying Comprehensive General/Automobile Liability coverage with Umbrella/Excess Liability coverage which provides no less than One Million (\$1,000,000) Dollars Single Limit Bodily Injury and Property Damage Liability Insurance for the Contractor will also be acceptable.
- f) The Owner may adjust the liability limits to coincide with local government procurement policies and practice within the limits of state and local law.

E. Builder's Risk Insurance

- a) Each Contractor shall maintain insurance from loss incurred by fire, lightning, extended coverage hazards, vandalism, theft, explosion and malicious mischief in the full amount of the Contract and such insurance shall cover all labor and material connected with the work, including materials delivered to the site, but not yet installed. This insurance shall be project specific and valued in the full amount of the contract.

F. The Policies as listed above shall all contain all the following special provisions:

- a) The Company agrees that thirty (30) days prior to cancellation or reduction of the insurance afforded by this policy with respect to the Contract involved, written notice will be mailed to ORCA.

TRAIL MAINTENANCE AND ENHANCEMENTS AT THE BAILEYS TRAIL SYSTEM
REQUEST FOR QUOTES
ATHENS-WAYNE OUTDOOR ASSET DEVELOPMENT CORPORATION

- b) The maintenance of such insurance as outlined herein shall in no way constitute a waiver of legal liability for damage to any adjoining buildings or their contents or the work and property of others on the site beyond the limits of insurance thus maintained. The Contractor shall hold the Owner free and harmless from any injury and damage resulting from the negligent or faulty performance of the Contract by the Contractor or by his/her Subcontractors.
- c) Each Contractor shall hold the Owner harmless from all payments for patents, either as royalty or otherwise, in the use of materials, methods, appliances, etc., that he may be in any way involved in or connected with any part of his work or the work of his Subcontractors.
- d) Prior to commencement of any work under the Contract, the Contractor shall furnish one (1) copy of the Declaration of Insurance as evidence of coverage.

ARTICLE 5 - SAFETY

- A. The Contractor will be responsible for initiating, maintaining and supervising all safety precautions and programs in connection with the Work. He/She will take all necessary precautions for the safety of, and will provide the necessary protection to prevent damage, injury, or loss to all employees on the work and other persons who may be affected thereby, and all the work and all materials or equipment to be incorporated therein, whether in storage on or off the site, and other property at the site or adjacent thereto, including trees, shrubs, lawns, walks, pavements, roadways, structures, and utilities not designated for removal, relocation, or replacement in the course of construction.
- B. The Contractor will erect and maintain, as required by the conditions and progress of the Work, all necessary safeguards for safety protection. He/She will notify owners of adjacent utilities when prosecution of the work may affect them.
- C. The Contractor shall comply with the safety standards guidelines provisions of applicable laws, building and construction codes as well as the requirements of the Occupational Safety and Health Act of 1970, as amended through January 1, 2004, and the requirements of Title 29 of the Code of Federal Regulations. The Contractor shall also comply with Chapter 4104.9-2 of the Ohio Revised Code prohibiting the Employment of Minors in Occupations Hazardous or Detrimental to their health and OSHA Part 1926, Safety and Health Regulations for Construction.

TRAIL MAINTENANCE AND ENHANCEMENTS AT THE BAILEYS TRAIL SYSTEM
REQUEST FOR QUOTES
ATHENS-WAYNE OUTDOOR ASSET DEVELOPMENT CORPORATION

- D. The Contractor shall maintain at his/her office or other well-known place at the job site, all articles necessary for giving first aid to the injured, and shall make standing arrangements for the immediate removal to a hospital or a doctor's car of persons (including employees) who may be injured at the job site. In no case shall employees be permitted to work at a job site before the employer has made a standing arrangement for removal of injured persons to a hospital or a doctor's care.
- E. Lights, signs and barricades shall be used to maintain traffic and safety for vehicular and pedestrian traffic during the course of this contract in accordance with the specifications.

ARTICLE 6 - PERMITS

The Contractor is responsible for obtaining and paying for all other necessary permits and licenses from the proper authorities. The Contractor shall give all notices and comply with all laws, ordinances, rules, and regulations bearing on the conduct of the work as drawn and specified. If the Contractor observes that the Contract Documents are at variance therewith, he/she shall promptly notify the Owner in writing.

ARTICLE 7 - SUPERVISION

- A. The Contractor will supervise and direct the work. He/She will be solely responsible for the means, methods, techniques, sequences, and procedures of construction. The Contractor will employ and maintain on the work site a qualified supervisor or superintendent who shall have been designated in writing by the Contractor at the pre-construction meeting as the Contractor's representative at the site. The Supervisor shall have full authority to act on behalf of the Contractor and communications given to the supervisor shall be as binding as if given to the Contractor. The supervisor shall be present and on the site at all times as required to perform adequate supervision and coordination of the work.
- B. The Owner and its representative will, at all times, have access to the work. In addition, authorized representatives and agents of any participating federal or state agency shall be permitted to inspect all work, materials, and payrolls, records of personnel, invoices of materials, and other relevant data and records. The Contractor will provide proper facilities for such access and observation of the work and also for any inspection or testing thereof.
- C. All construction as proposed along all City, Township, County, State and Federal roads including storage and stockpiling of materials, is to be conducted within the limits of the public right-of-way. Bracing, sheeting and shoring shall be used to keep all construction

TRAIL MAINTENANCE AND ENHANCEMENTS AT THE BAILEYS TRAIL SYSTEM
REQUEST FOR QUOTES
ATHENS-WAYNE OUTDOOR ASSET DEVELOPMENT CORPORATION

work within the construction limits unless work agreements are secured from the adjacent property owners. It is the Contractor's responsibility to secure these work agreements, if deemed necessary. Copies of the work agreements shall be delivered to the Engineer and the Owner prior to any work beginning on the affected property.

ARTICLE 8 - CLAIMS AGAINST CONTRACTOR

The Contractor shall indemnify and save the Owner or the Owner's agents harmless from all claims growing out of the lawful demands of Subcontractor's laborers, workmen, mechanics, materialmen, and furnishers of machinery and parts thereof, equipment, tools, and all supplies, incurred in the furtherance of the performance of the work. The Contractor shall, at the Owner's request, furnish satisfactory evidence that all obligations of the nature designated above have been paid, discharged, or waived. If the Contractor fails to do so, the Owner, may, after having notified the Contractor, wither pay unpaid bills or withhold from the Contractor's unpaid compensation a sum of money deemed reasonably sufficient to pay any all such lawful claims until satisfactory evidence is furnished that all liabilities have been fully discharged whereupon payment to the Contractor shall be resumed, in accordance with the terms of the Contract Documents, but in no event shall the provisions of this sentence be construed to impose any obligations upon the Owner to either the Contractor, his Surety, or any third party. In paying any unpaid bills of the Contractor, any payment so made by the Owner shall be considered as a payment made under the Contract Documents by the Owner to the Contractor and the Owner shall not be liable to the contractor for any such payments in good faith.

ARTICLE 9 - SUBCONTRACTING

- A. Neither the Contractor nor the Owner shall sell, transfer, assign, or otherwise dispose of his right, title, or interest therein, or his obligations thereunder.
- B. The Contractor shall not sublet, sell, transfer or assign any portion of the contract without written consent of the Owner or his/her designated agent. When such consent is given, the Contractor will be permitted to sublet a portion thereof, but shall perform with his/her own organization, work amounting to no less than fifty percent of the total contract cost, except that any item designated in the contract before computing the amount of work required to be performed by the Contractor with his/her own organization. No subcontract, or transfer of contract, shall in any way release the Contractor of his/her liability under the contract and bonds.
- C. The Contractor shall not award work to Subcontractor(s) without prior written approval of the Owner, after verification by the Ohio Department of Development of the subcontractor's current eligibility status, and after submission of all certifications as required in *III. BID FORMS*. The Contractor shall be fully responsible to the Owner for the acts and omissions of the subcontractor(s), and of the persons either directly or

TRAIL MAINTENANCE AND ENHANCEMENTS AT THE BAILEYS TRAIL SYSTEM
REQUEST FOR QUOTES
ATHENS-WAYNE OUTDOOR ASSET DEVELOPMENT CORPORATION

indirectly employed by them, as he is for the acts and omissions of persons directly employed by him/her.

ARTICLE 10 - CHANGE OF WORK

- A. The Owner reserves the right to make, at any time during the progress of the work, such increases or decreases in quantities and such alterations in details of work as may be deemed necessary or desirable. Owner intends to Contract within the project budget and minimize or not utilize the right to increase or decrease quantities outside extenuating circumstances. Any increases or decreases and alterations shall not invalidate the contractor nor release the surety, the Contractor agrees to perform the work as altered, the same as if it had been a part of the original contract.
- B. Authorized alterations in plans or quantities of work involving work not covered by unit prices in the proposal are paid for as stipulated in the change order authorizing such work.
- C. No changes in work covered by the approved Contract shall be made without having prior written approval of the Owner.

ARTICLE 11 - TERMINATION

After ten (10) days from delivery of a Written Notice to the Contractor, the Owner may, without cause and without prejudice to any other right or remedy, elect to terminate the Contract. In such case, the Contractor shall be paid for all work executed and any expense sustained plus reasonable profit, unless such termination was due to the act or conduct of the Contractor.

ARTICLE 12 - CORPORATE LICENSE

Bidders must comply with the statutory requirements of the State of Ohio relative to the licensing of corporations or other entities organized under the laws of any other state or country and other pertinent requirements for doing business in Ohio. Contractor shall secure and provide a copy of their Corporate License prior to receiving a Notice of Award.

TRAIL MAINTENANCE AND ENHANCEMENTS AT THE BAILEYS TRAIL SYSTEM
REQUEST FOR QUOTES
ATHENS-WAYNE OUTDOOR ASSET DEVELOPMENT CORPORATION

ATTACHMENT A. BAILEYS CONSTRUCTION DOCUMENTS

Bailey Tract Trail System Construction Documents

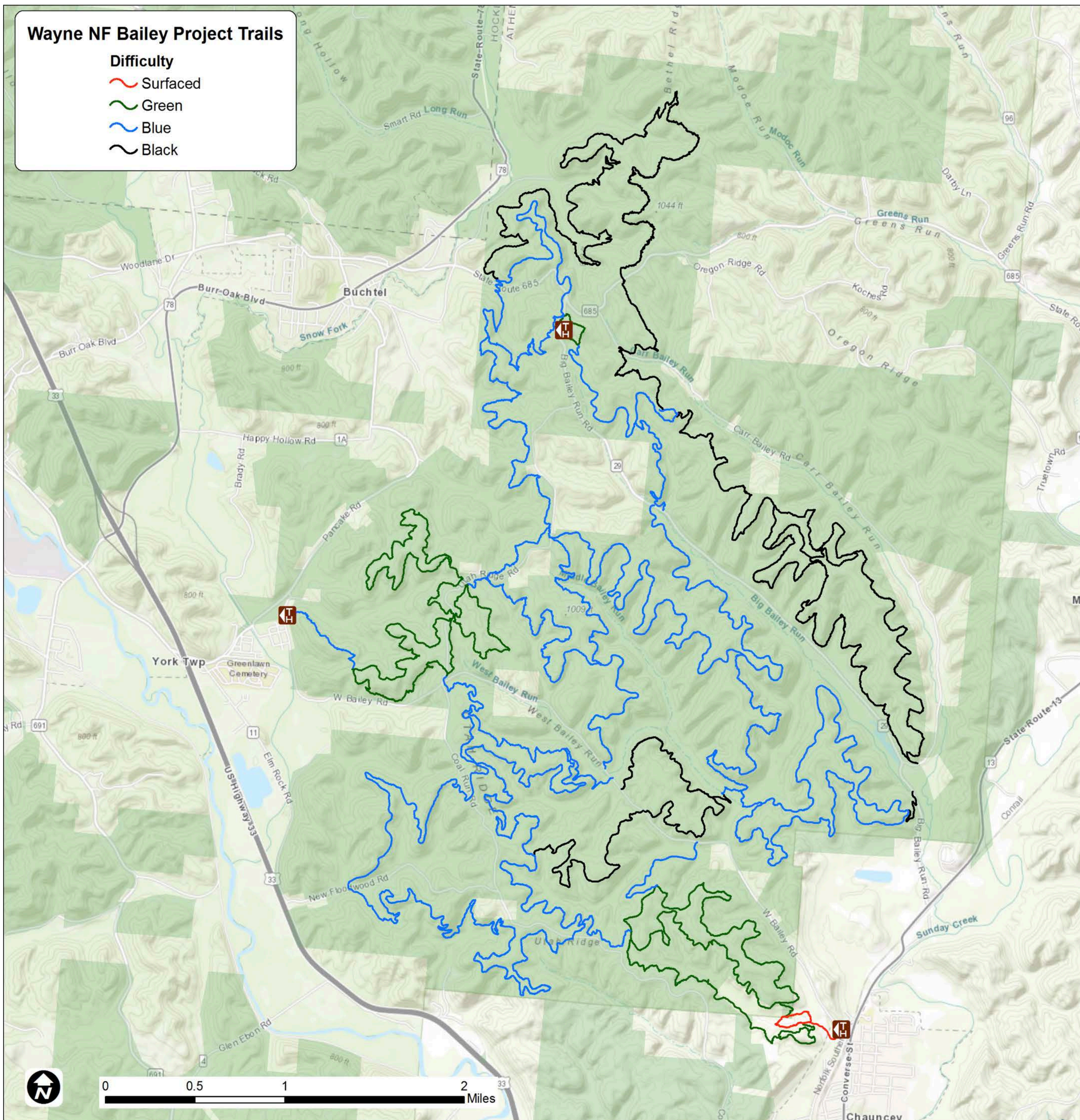
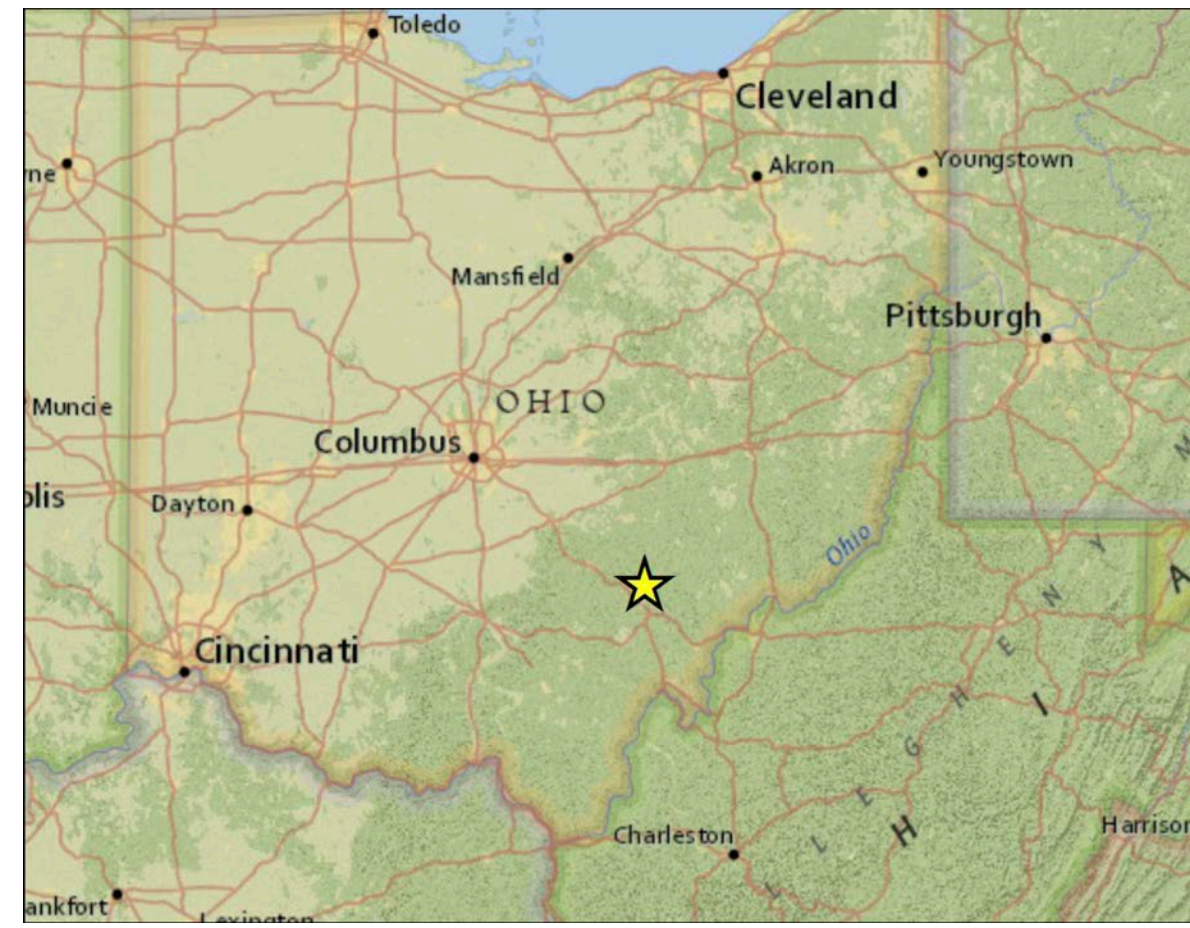

Table of Contents

- A1: Cover Page
- A2: Panel Locator Map & Summary Tables
- A3: Panel A
- A4: Panel B
- A5: Panel C
- A6: Panel D
- A7: Construction Notes
- A8: Details 1 - Rolling Contour Trail
- A9: Details 2 - Puncheon and Bridges
- A10: Details 3 - Flagstone Armored Crossing
- A11: Details 4 - Stone Pitched Armored Crossing
- A12: Details 5 - Arched Half Culvert



PREPARED BY:
APPLIED TRAILS RESEARCH
 1310 North Allen St
 State College, PA 16803
 appliedtrailsresearch.com

FOR:
 Wayne National Forest
 Athens Ranger District
 13700 US Highway 33
 Nelsonville, OH
 45764

ISSUE:
 1.25.19

PROJECT:
 Bailey Tract Trail System
 Construction Documents



Panel Locator Map



Summary Table

Trail Type

Surfaced	3,839 feet
Less Difficult (green)	79,243 feet
More Difficult (blue)	205,516 feet
More Difficult Directional (blue)	33,471 feet
Most Difficult (black)	92,626 feet
Most Difficult Directional (black)	26,671 feet

Crossing Type

Bridges	10 total
Puncheon	1500 feet
Rock Armor	120 feet
At Grade/Culvert	115 total (75% at grade, 25% culvert desired)

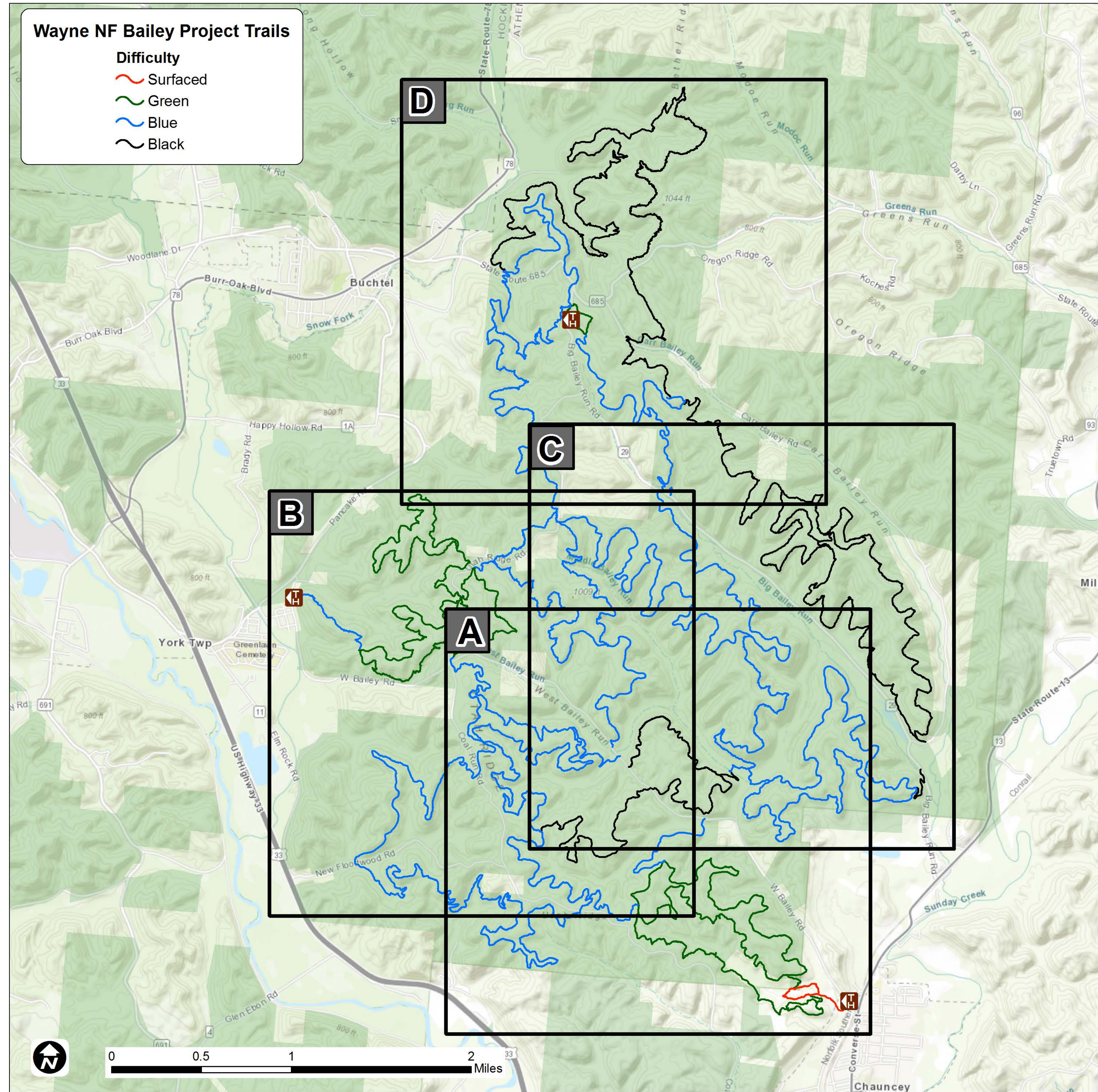

Panel A

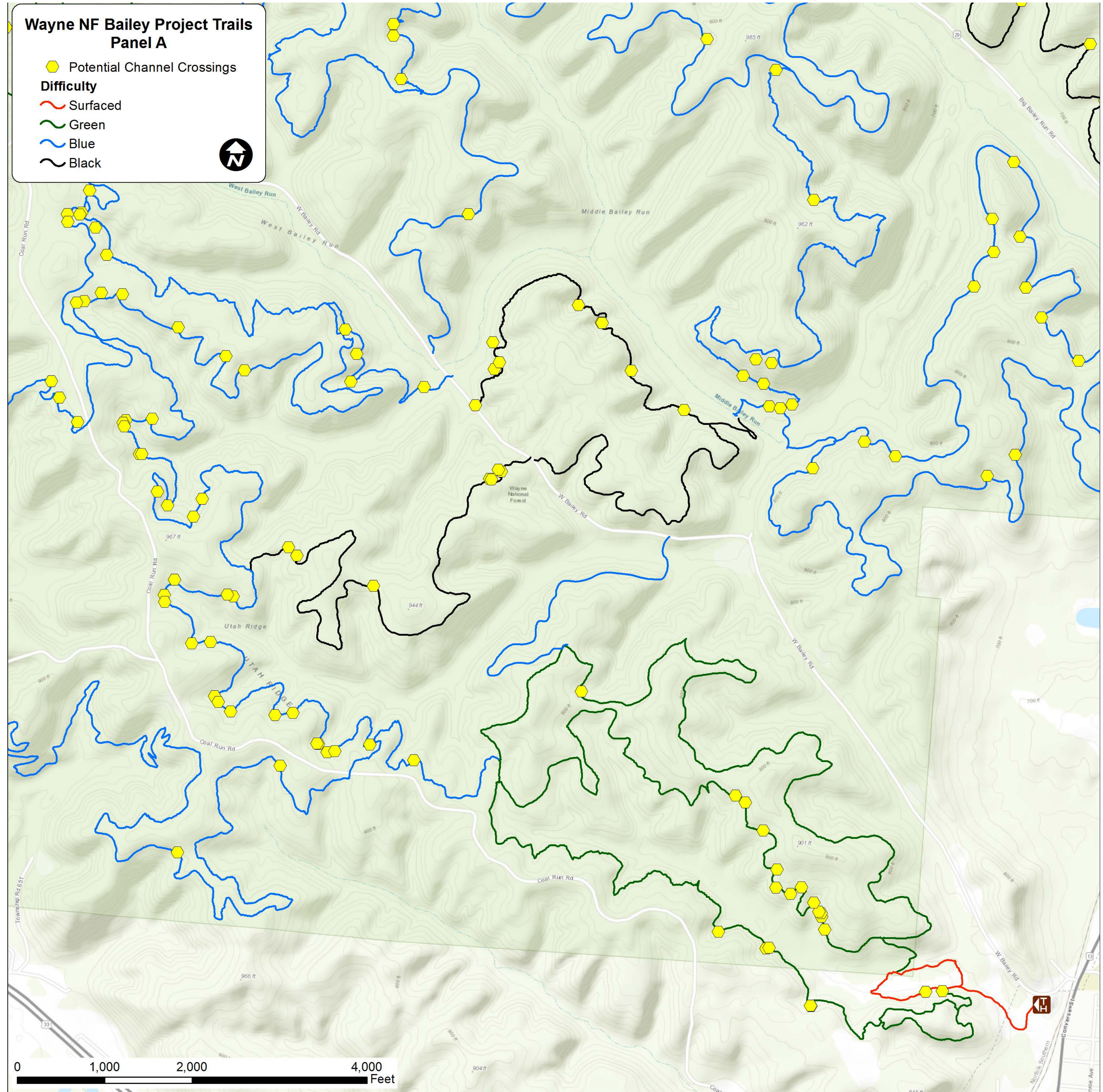
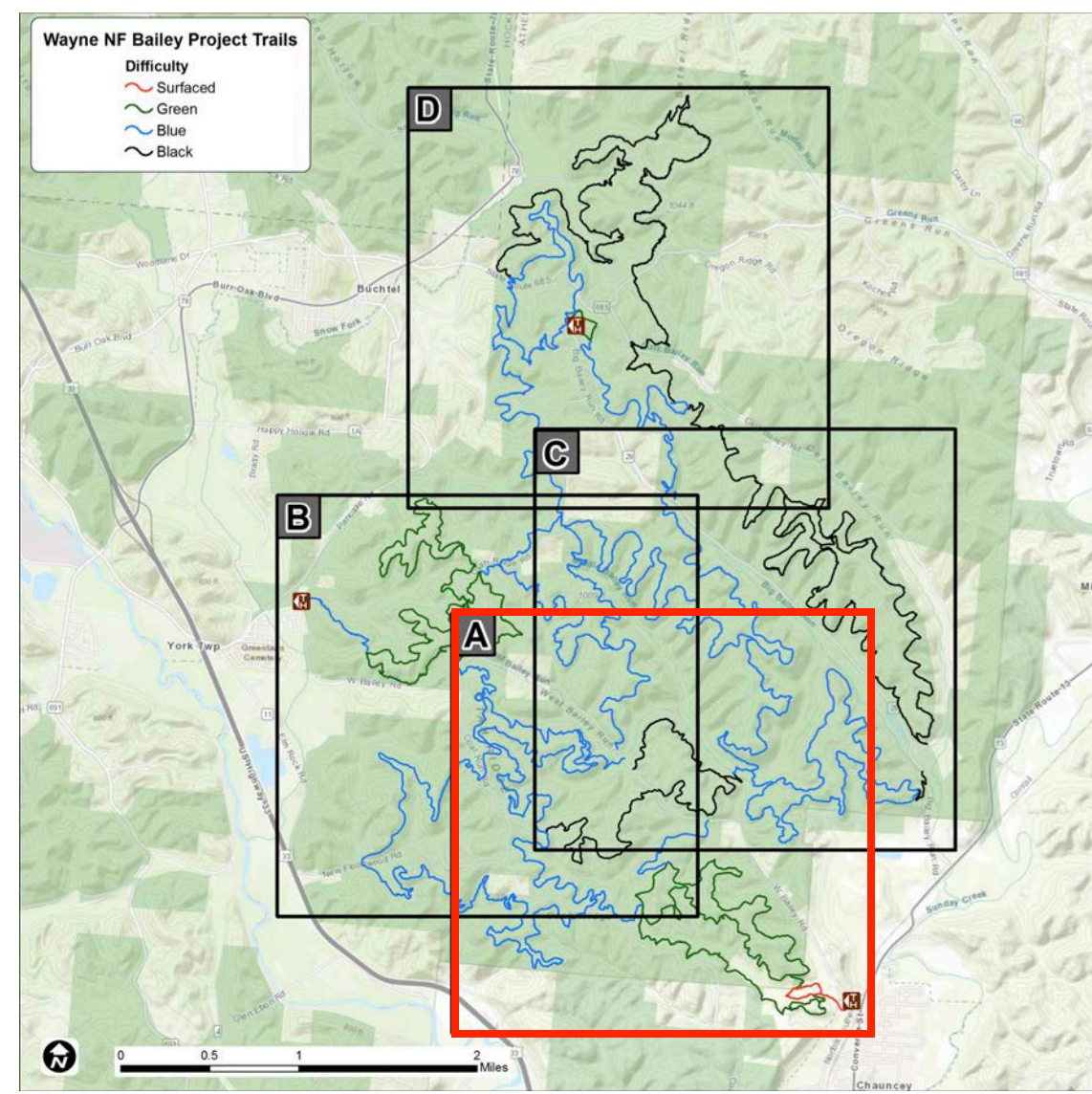

PREPARED BY:
APPLIED TRAILS RESEARCH
 1310 North Allen St
 State College, PA 16803
 appliedtrailsresearch.com

FOR:
 Wayne National Forest
 Athens Ranger District
 13700 US Highway 33
 Nelsonville, OH
 45764

ISSUE:
 1.25.19

PROJECT:
 Bailey Tract Trail System
 Construction Documents



Panel B

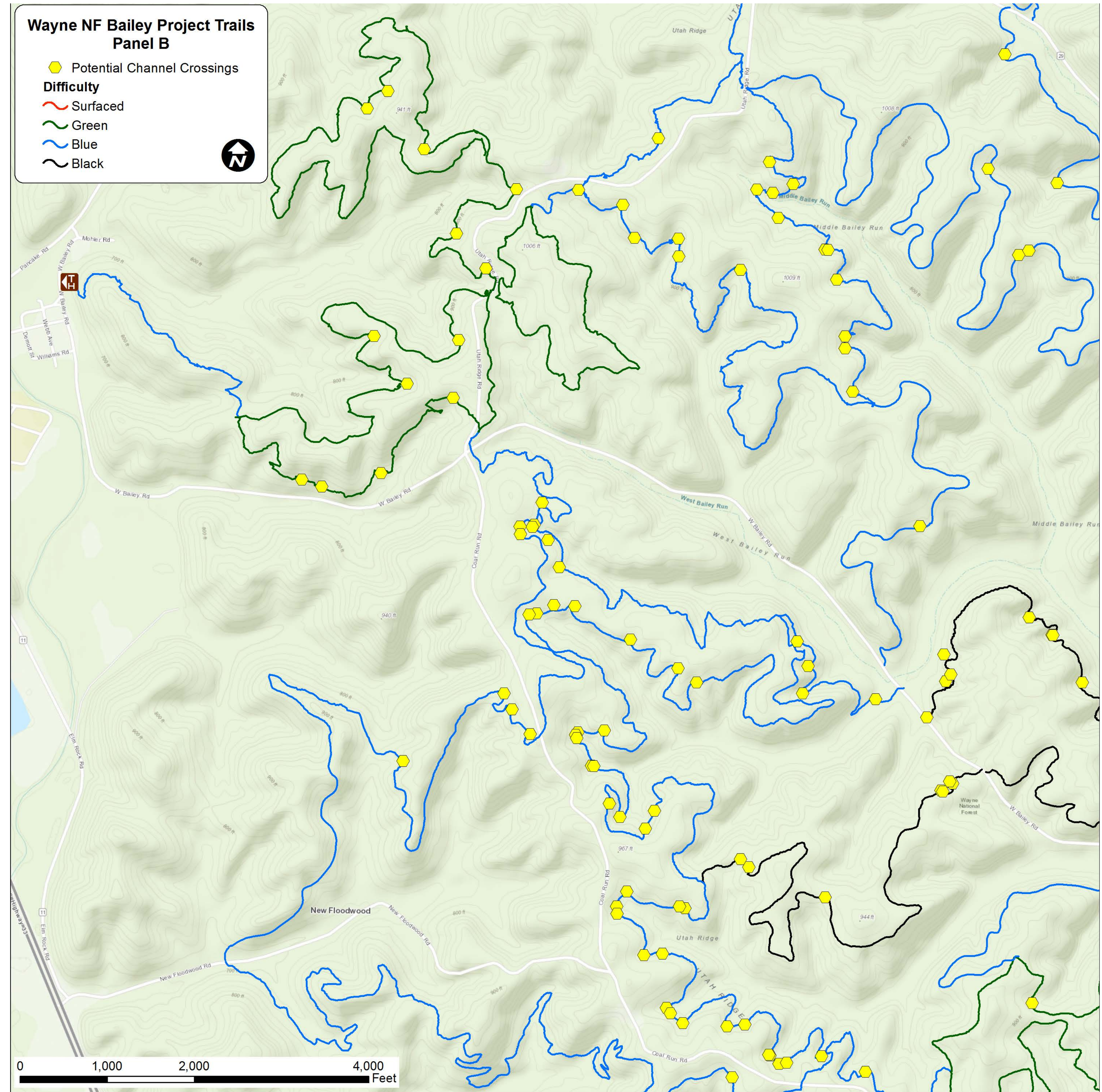
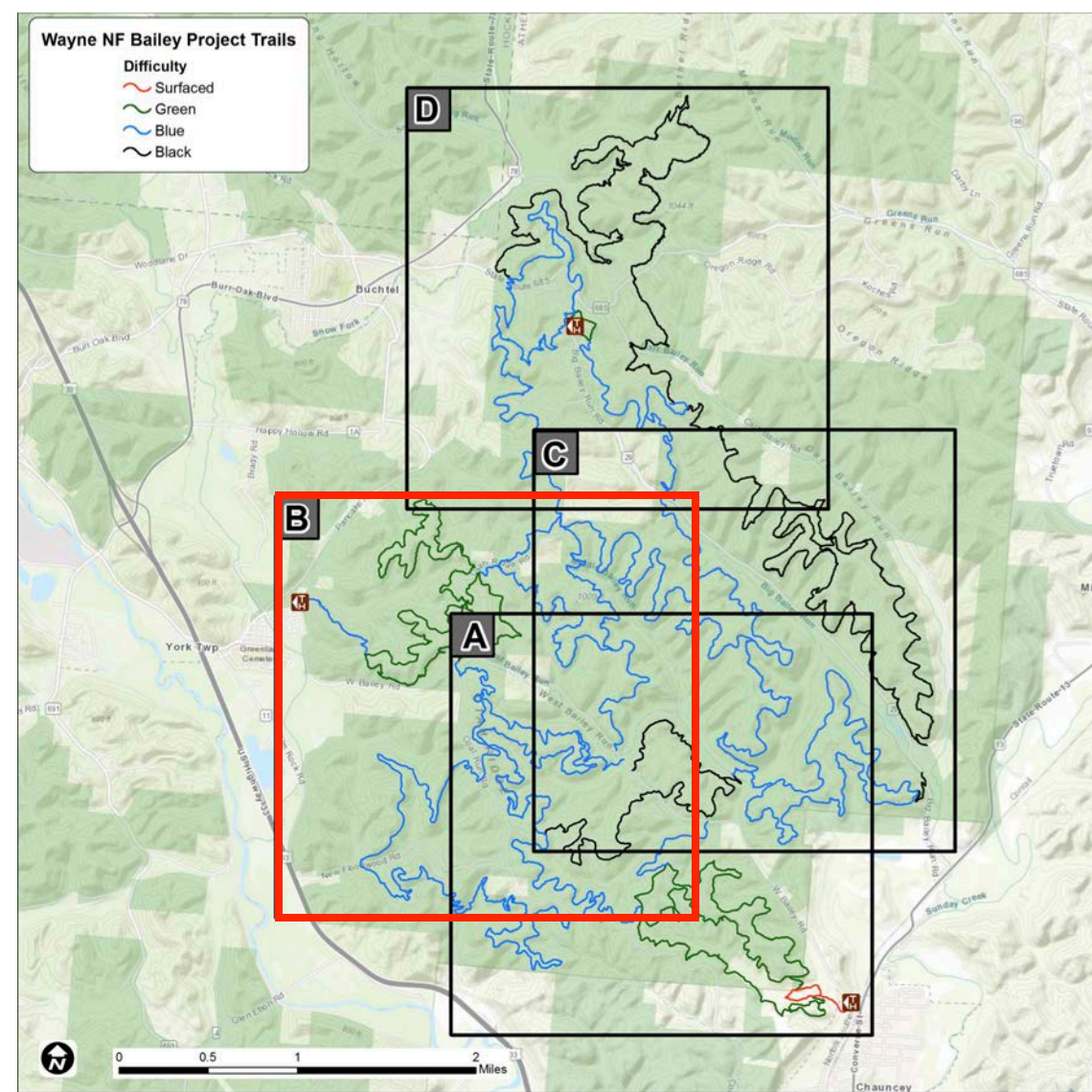
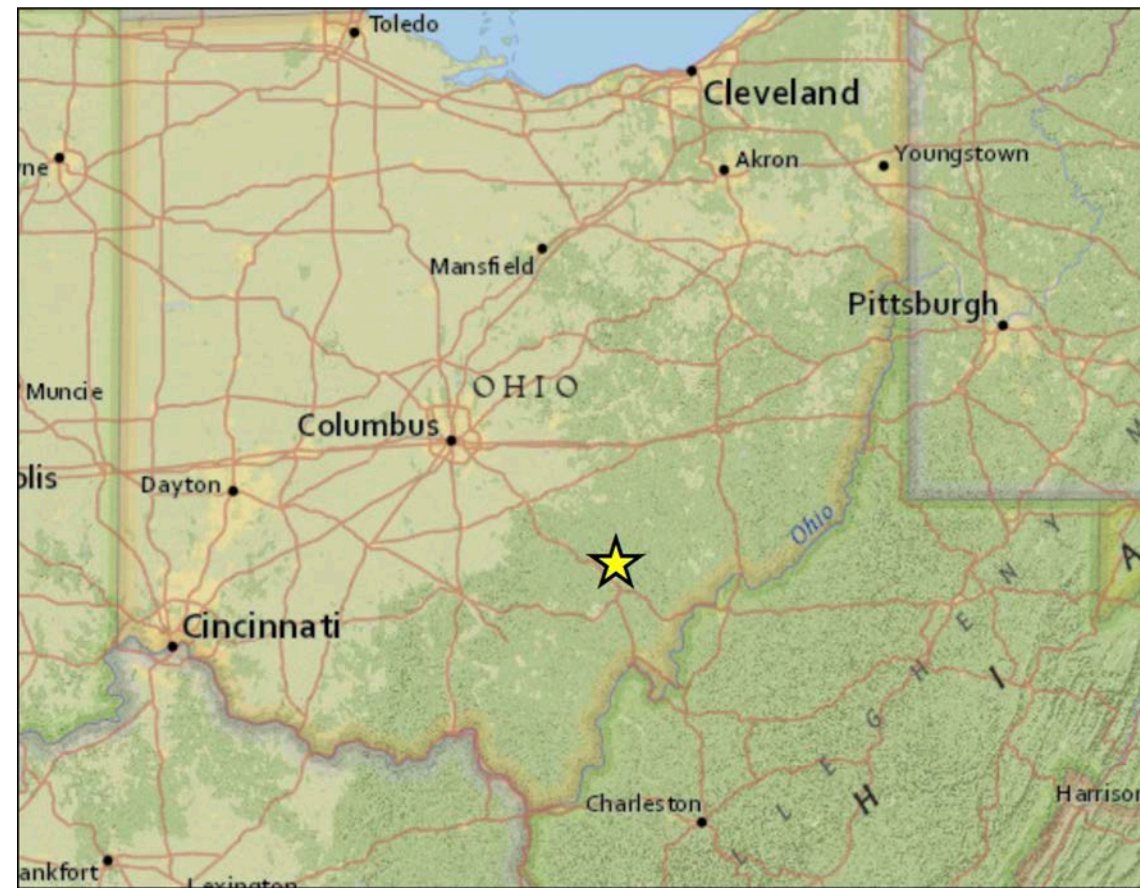

PREPARED BY:
APPLIED TRAILS RESEARCH
 1310 North Allen St
 State College, PA 16803
 appliedtrailsresearch.com

FOR:
 Wayne National Forest
 Athens Ranger District
 13700 US Highway 33
 Nelsonville, OH
 45764

ISSUE:
 1.25.19

PROJECT:
 Bailey Tract Trail System
 Construction Documents

Panel C

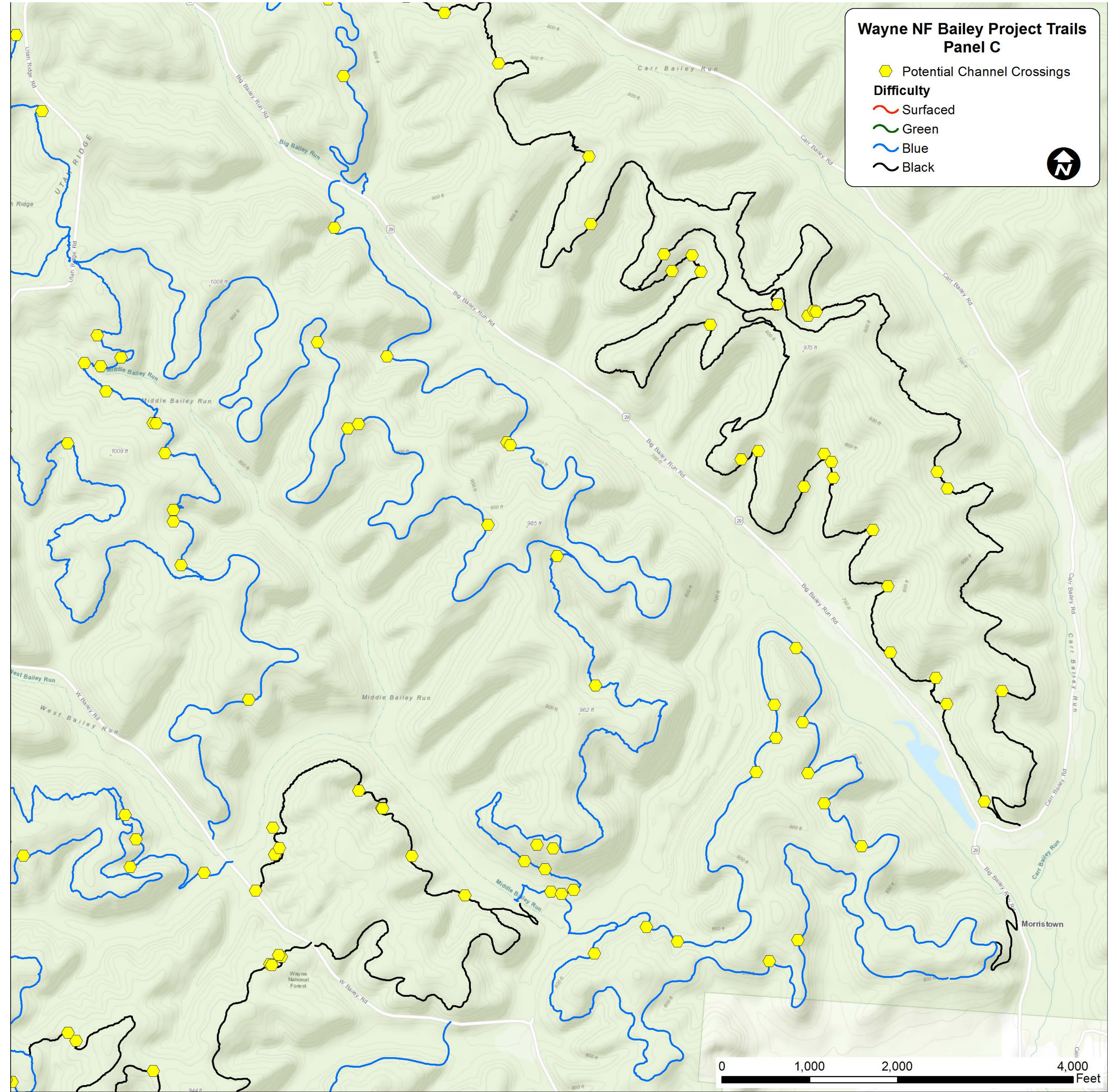
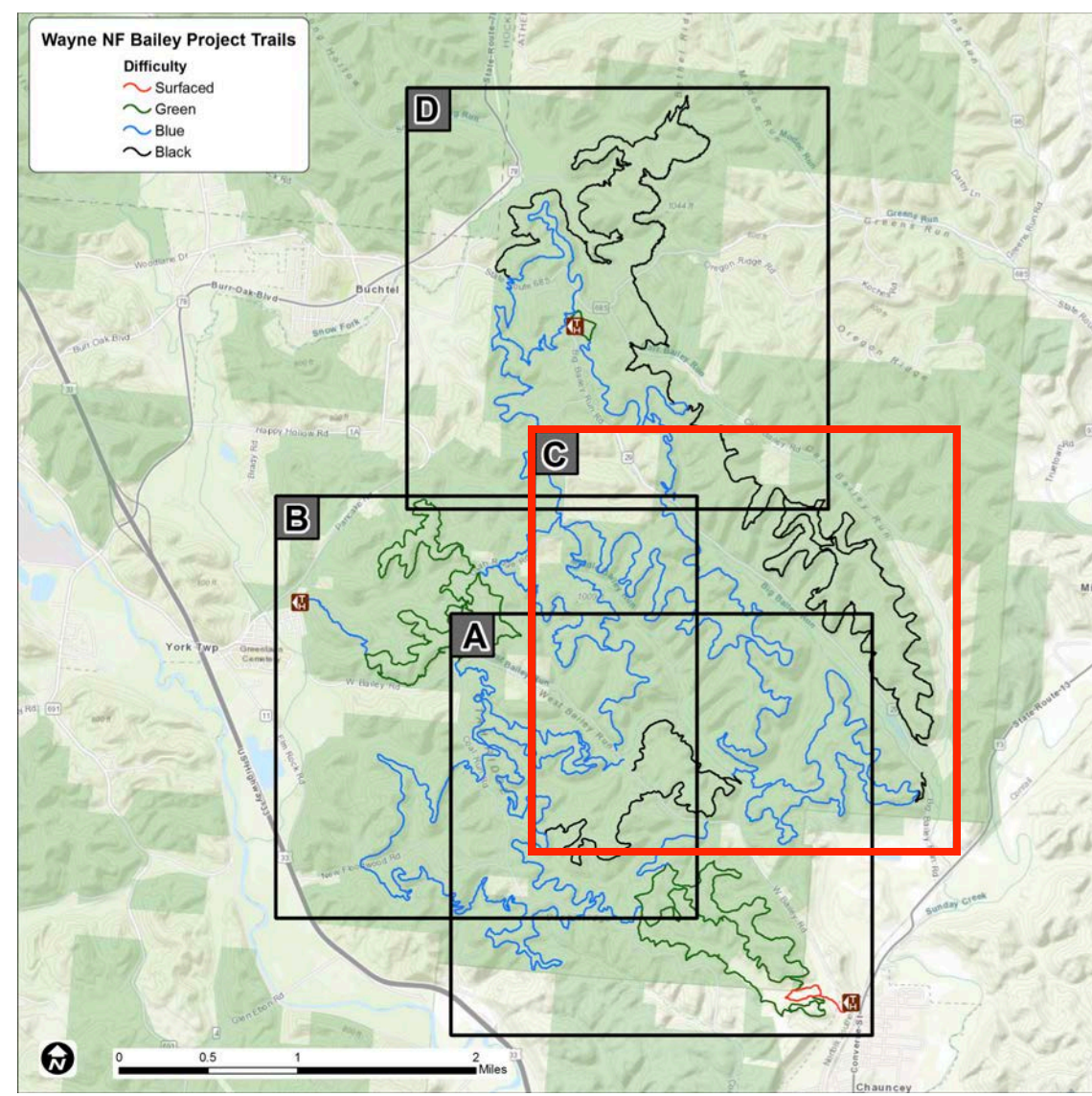

PREPARED BY:
APPLIED TRAILS RESEARCH
 1310 North Allen St
 State College, PA 16803
 appliedtrailsresearch.com

FOR:
 Wayne National Forest
 Athens Ranger District
 13700 US Highway 33
 Nelsonville, OH
 45764

ISSUE:
 1.25.19

PROJECT:
 Bailey Tract Trail System
 Construction Documents

Panel D

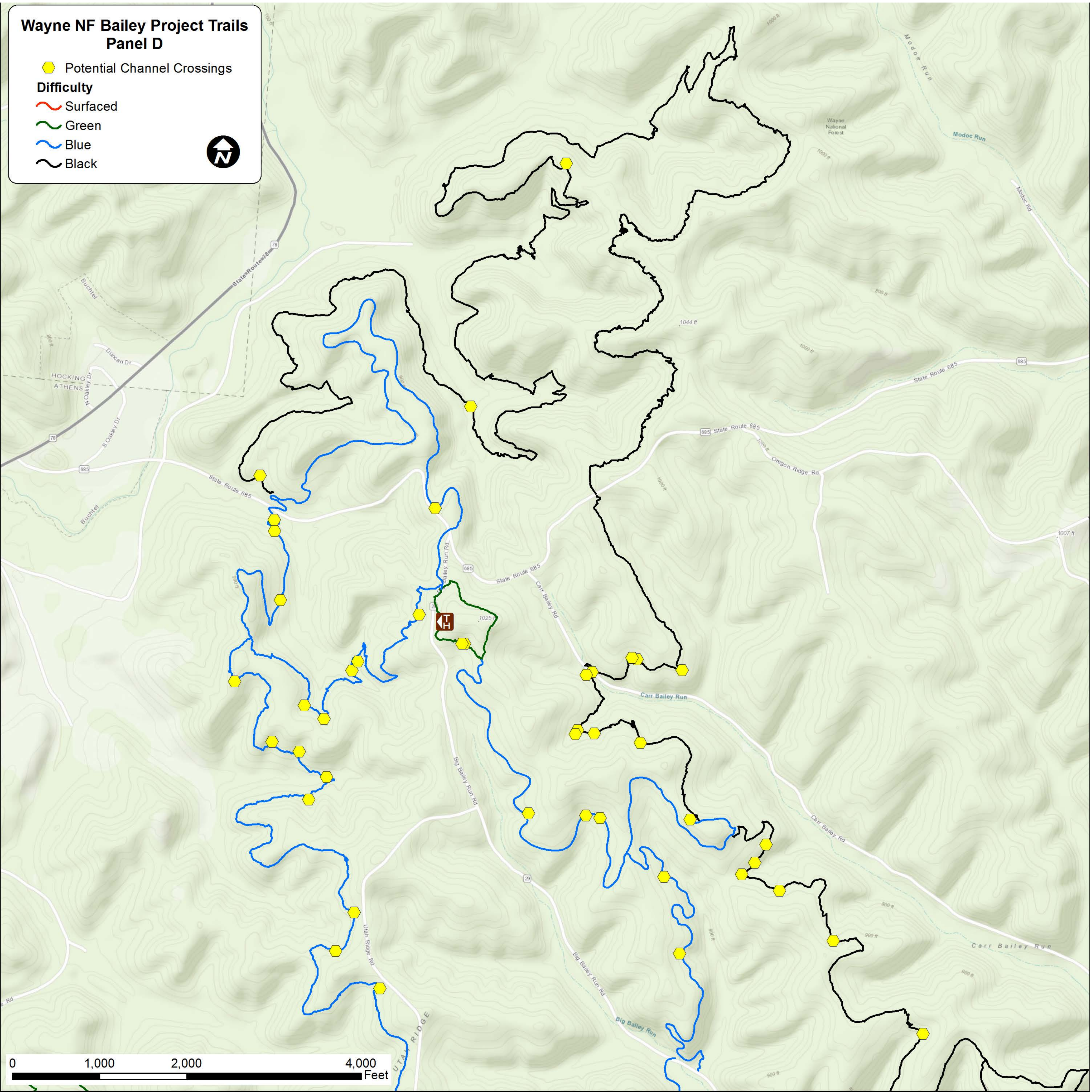
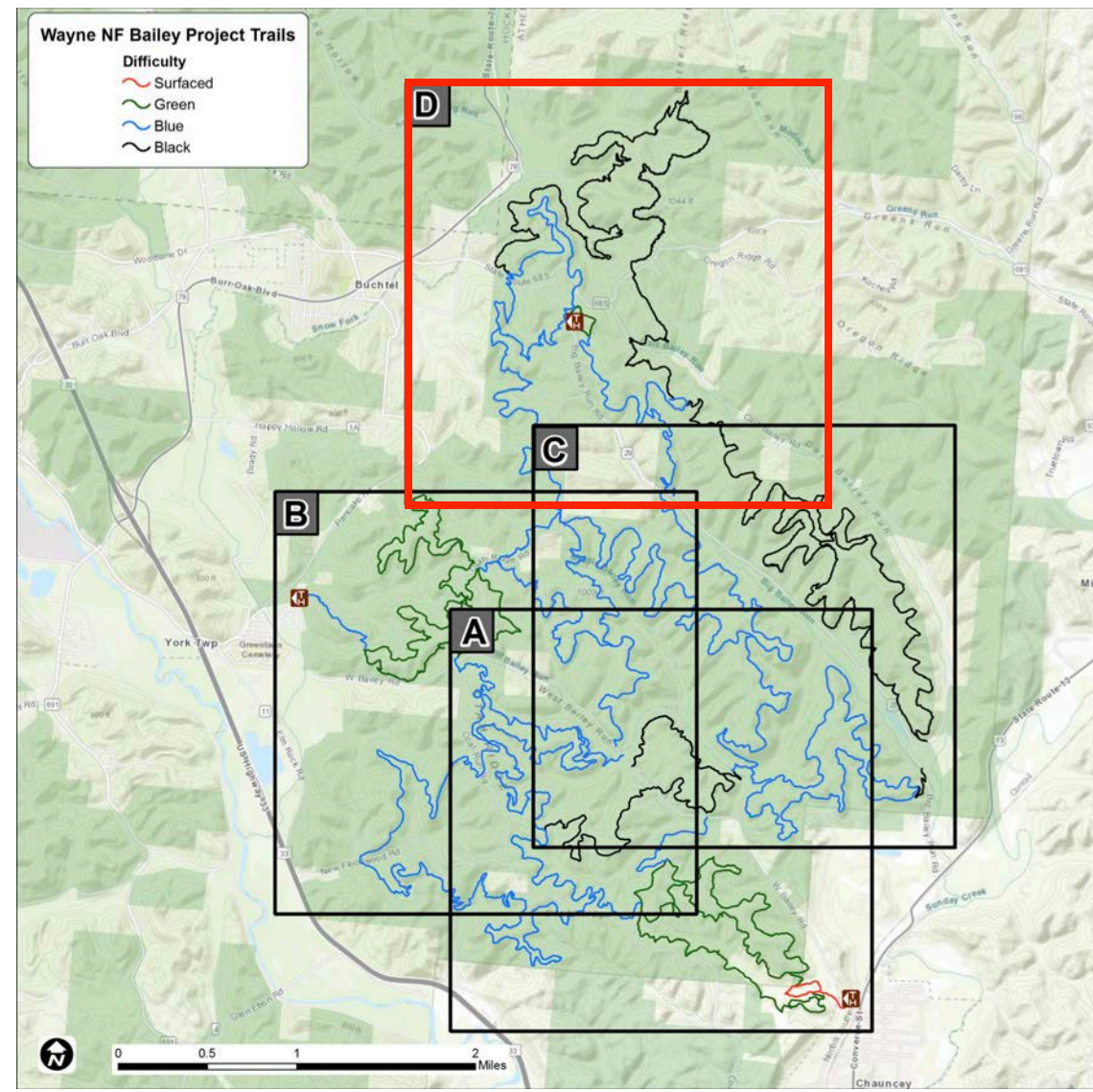

PREPARED BY:
APPLIED TRAILS RESEARCH
 1310 North Allen St
 State College, PA 16803
 appliedtrailsresearch.com

FOR:
 Wayne National Forest
 Athens Ranger District
 13700 US Highway 33
 Nelsonville, OH
 45764

ISSUE:
 1.25.19

PROJECT:
 Bailey Tract Trail System
 Construction Documents

Construction Notes

SEQUENCE OF CONSTRUCTION:

General Notes

1. At least 7 days prior to initiating any earth disturbance (corridor and/or tread development), the owner and/or construction manager shall invite contractors, the USFS, appropriate officials to an on-site preconstruction meeting.
2. All earth disturbance activities shall proceed in accordance with the sequence provided on the plan drawings and construction notes. Deviation from that sequence must be approved in writing from USFS to implementation.
3. Contractor will perform controls necessary for the execution of the work (even if not specifically mentioned) and provide additional controls as required by unforeseen conditions. Any additional controls will be submitted in writing to USFS via the owner/construction manager.

TRAIL CONSTRUCTION NOTES

1. Trail construction will be conducted by a professional firm that can demonstrate significant and successful experience in the field of mountain bike-optimized natural surface trail development.
2. Construction of trail tread and attendant features (i.e. puncheon, bridge, culvert, and rock armored segments) will be in accordance with the general specifications presented within this document and fundamentally based on sustainable trail design principles promulgated by credible, recognized printed source material, including the International Mountain Bicycling Association's handbooks, *Trail Solutions* and *Managing Mountain Biking*, and the USDA Forest Service's *Trail Construction and Maintenance Notebook*.
3. Trail corridor will be cleared to a width in accordance with the specifications. Stems larger than 6" dbh will not be removed until approved by the construction manager or USFS. All cut materials longer than 5' in length will be bucked to less than 5' and utilized with nearby native materials to stabilize excavated spoils. All vegetative materials will be removed from the trail tread. Any stumps developed in the corridor development will be excavated and removed from the corridor.
4. Trail tread development will consist of full bench trail construction, devoid of fill material for use in the tread surface (berms and roller features excepted), and mechanically compacted following construction. Acceptable protrusion height above the trail tread for natural features such as rocks or roots will be in accordance with the specifications of the particular trail type (i.e. least difficult, more difficult, most difficult) being constructed. Tread will be constructed with a 3-10% cross slope, except where features are constructed for the purpose of keeping riders on the trail (i.e. berms, insloped corners, and constructed features).
5. Grade reversals will be located at less than 100' intervals and should have broad drains (6-10') with cross slopes of 10-15%. Subsequent reversals in grade should also be broad (10-25') and compacted with leading face and transition field-fit to match the desired trail experience (i.e. low and rolling on least difficult trails, rollable with the ability to jump on more difficult trails, and jump-optimized on most difficult trails).
6. Backslopes should blend with surrounding hillslope gradient and finished to tread specifications. In the case of inside turns, backslope should be optimized for utility as a riding/tread surface and blended with trail tread to provide smooth transitions.
7. Excavated spoils shall be distributed such that no berm is present on the downslope edge of the trail tread unless it is created for the purpose of a trail feature, in which case it will be preceded upslope by a grade reversal and compacted as trail tread.

8. Spoils will be sufficiently distributed downslope a.) with a depth not greater than 4" and b.) shall not be deposited in active drainages (i.e. stream bed and bank structure or incised linear flow pattern) or locations demonstrating characteristics of standing water (i.e. presence of standing water during construction, darkened leaves or water lines on trees indicating standing water for significant portions of time). If situation cannot be attained, spoil materials will be bucketed and dispersed in a nearby location that meets these conditions.
9. Following spoils dispersal, downslope and backslope areas will be immediately covered with native seed and mulch materials stockpiled during trail corridor clearing activities.
10. For hard armoring techniques, rock will be collected by hand within 50' of the trail centerline.
11. Turns in the trail tread that result in crossing the fall-line of the hillslope will be constructed according to the trail tread specifications with the addition of a grade reversal upslope and prior to the turn, all fill and/or retaining walls necessary to stabilize the turn, drainage features necessary to remove water from the turn area (i.e. insloped drain or crowned turn platform), and a grade reversal downslope/following the turn. Insloped and/or super-elevated turns shall be field-fit and constructed, where necessary, to assist riders in remaining in the center of the trail tread and maintaining momentum.
12. Alternative riding lines and/or technical trail features, if developed, will be designed in a collaborative manner with approval necessary from the construction manager and USFS, and will be developed based on available time and funds. All features will adhere to standard construction best practices for dry stack masonry. Approaches to and exits from features will be field-fit to minimize vegetation and hydrologic impacts. Fall zones for features higher than 12" above the surrounding topography will be cleared of loose, sharp rocks or other materials that could focus rider impacts for a lateral distance of 10' from the feature.

EROSION AND SEDIMENTATION POLLUTION CONTROL NOTES

1. At least 7 days prior to initiating any earth disturbance activities (trail corridor clearing and grubbing and trail tread excavation), the owner and/or construction manager shall invite all contractors, USFS, appropriate municipal and county officials, including County Conservation District officer, to an on-site preconstruction meeting.
4. All earth disturbance activities shall proceed in accordance with the sequence provided in the General and Trail Construction Notes and accompanying specifications. Deviation from that sequence must be approved in writing from the construction manager or USFS prior to implementation.
5. Clearing, grubbing, and topsoil stripping shall be limited to the trail corridor.
6. Borrow pit development shall take place within 50' of the trail centerline with all borrow pits and access routes stabilized and naturalized (see Trail Construction Notes) following use.
7. Immediately upon discovering unforeseen circumstances posing the potential for accelerated erosion and/or sediment pollution, the contractor shall implement appropriate BMPs to minimize the potential for erosion and sediment pollution and notify the construction manager or USFS.
8. All building materials and wastes must be removed from the site and recycled or disposed of in accordance with local regulations. No building materials, wastes, or unused building materials shall be burned, buried, dumped, or discharged at the site.
9. **Trail tread construction disturbances shall be permanently stabilized on a daily basis**, as prescribed in the Construction Notes and specifications. Trail corridor clearing and grubbing may take place without additional stabilization activities.
10. Sediment tracked onto any public roadway or parking area shall be returned to the construction site by the end of each work day and disposed in the manner presented for spoils stabilization in the Trail Construction Notes. In no case shall the sediment be washed, shoveled, or swept into any roadside ditch, storm sewer, or surface water.
11. Upon completion of all earth disturbance activities and permanent stabilization of all disturbed areas, the contractor shall contact the the construction manager or USFS to schedule a final inspection.

RECYCLING AND DISPOSAL OF CONSTRUCTION WASTE

1. Recycling and disposal of materials associated with this project shall be undertaken in accordance with local rules and regulations.
2. Except for items indicated to be reused, salvaged, reinstalled, or otherwise indicated to remain on the property, demolished or excavated materials shall be removed from the site.
3. Materials slated for removal from the site shall be disposed of in accordance with any and all applicable municipal or other government agency current regulations.
4. Debris shall not be permitted to accumulate on the job site. Dust and dirt shall be held to a minimum during construction.
5. At the completion of work, the entire work area shall be clean and left in a neat condition, free of waste and debris.



PREPARED BY:
APPLIED TRAILS RESEARCH
1310 North Allen St
State College, PA 16803
appliedtrailsresearch.com

FOR:
Wayne National Forest
Athens Ranger District
13700 US Highway 33
Nelsonville, OH
45764

ISSUE:
1.25.19

PROJECT:
Bailey Tract Trail System
Construction Documents



Details 1. Rolling Contour Trail

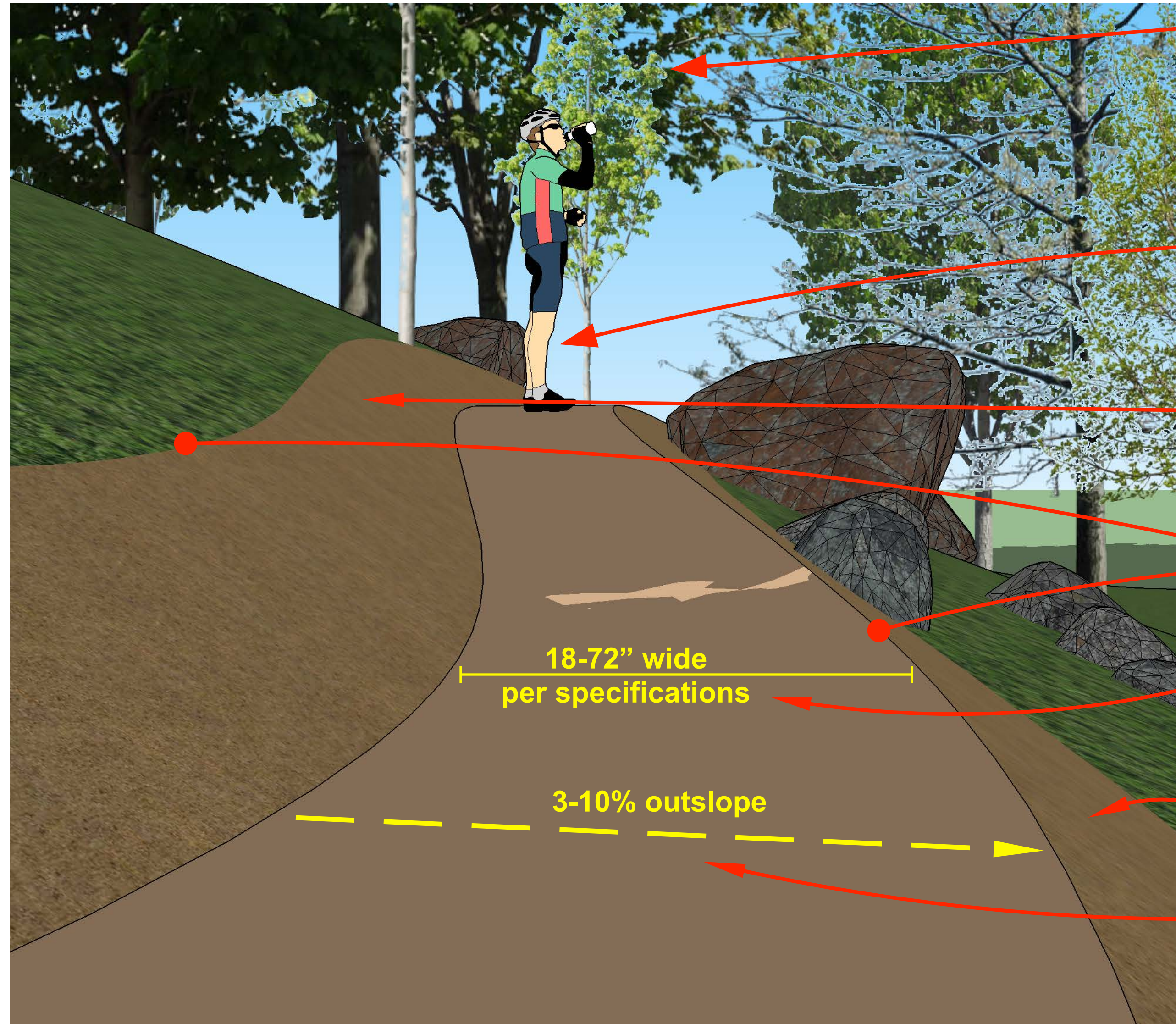

Retain entire forest canopy/riparian buffer, no tree greater than 6" DBH to be removed

Rocks and trees used as trail anchors

Backslope blended into hillside, covered with leaf litter, native seed bank following construction

Critical point is rounded

Trail tread has gentle gradient (2-15%, not more than half prevailing hillslope grade), 18-72" wide (per specifications) with minimal compaction

Spoils dispersed evenly, less than 4" deep, covered with leaf litter, native seed bank

Trail tread is outsloped 3-10%

18-72" wide
per specifications

3-10% outslope

Rolling Contour - Outsloped Tread with frequent grade reversals to force water to drain off the trail, maintaining natural hydrologic flow patterns and watersheds.

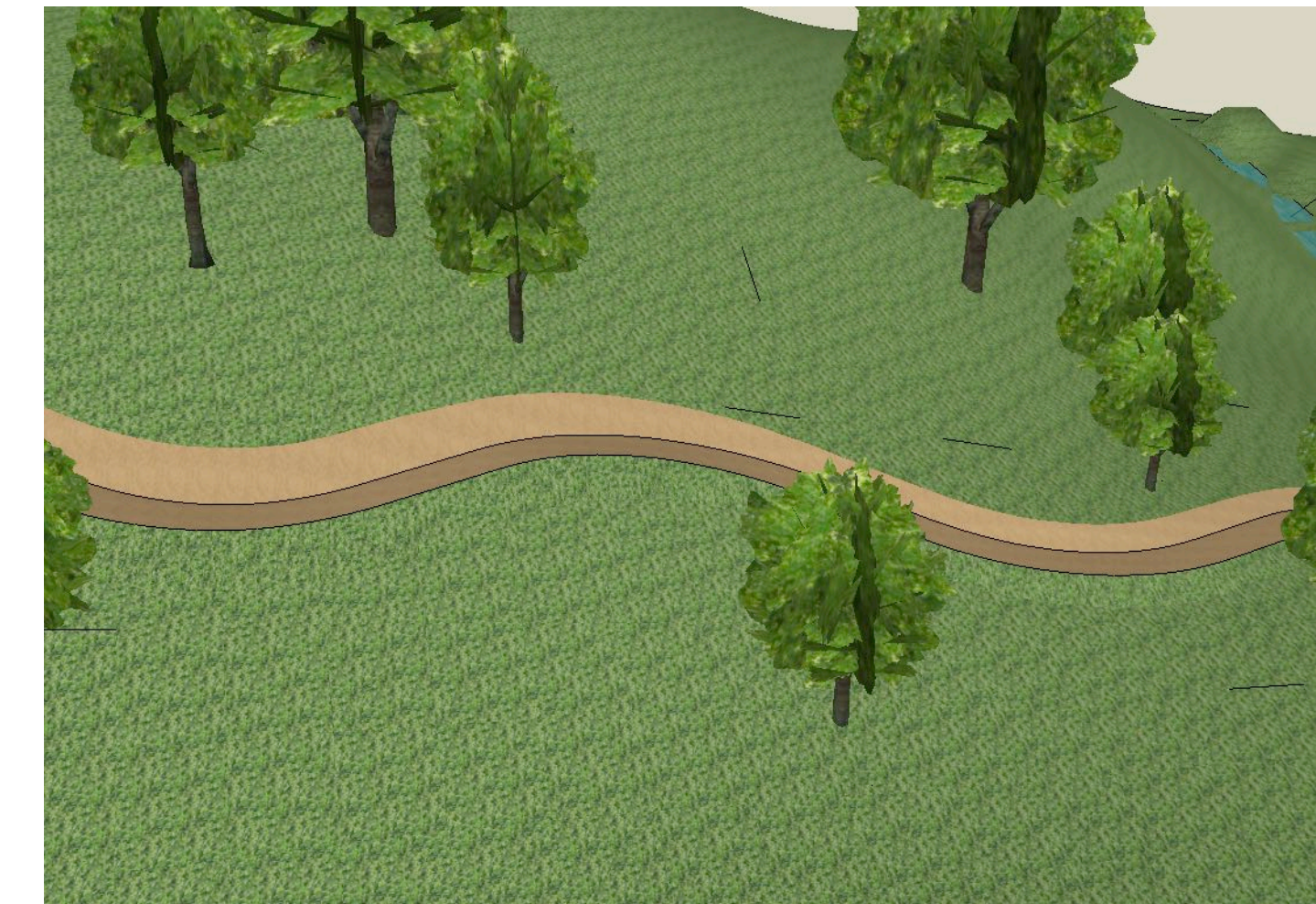

Rolling Contour - Insloped Turn with Outsloped Grade Reversal to keep riders on trail and reduce lateral displacement of soil. Drains in grade reversals need to be 10-15% outsloped.



Grade
Reversal

Drain

Insloped Trail



PREPARED BY:
APPLIED TRAILS RESEARCH
1310 North Allen St
State College, PA 16803
appliedtrailsresearch.com

FOR:
Wayne National Forest
Athens Ranger District
13700 US Highway 33
Nelsoville, OH
45764

ISSUE:
1.25.19

PROJECT:
Bailey Tract Trail System
Construction Documents

Details 2. Puncheon and Bridge

Top View

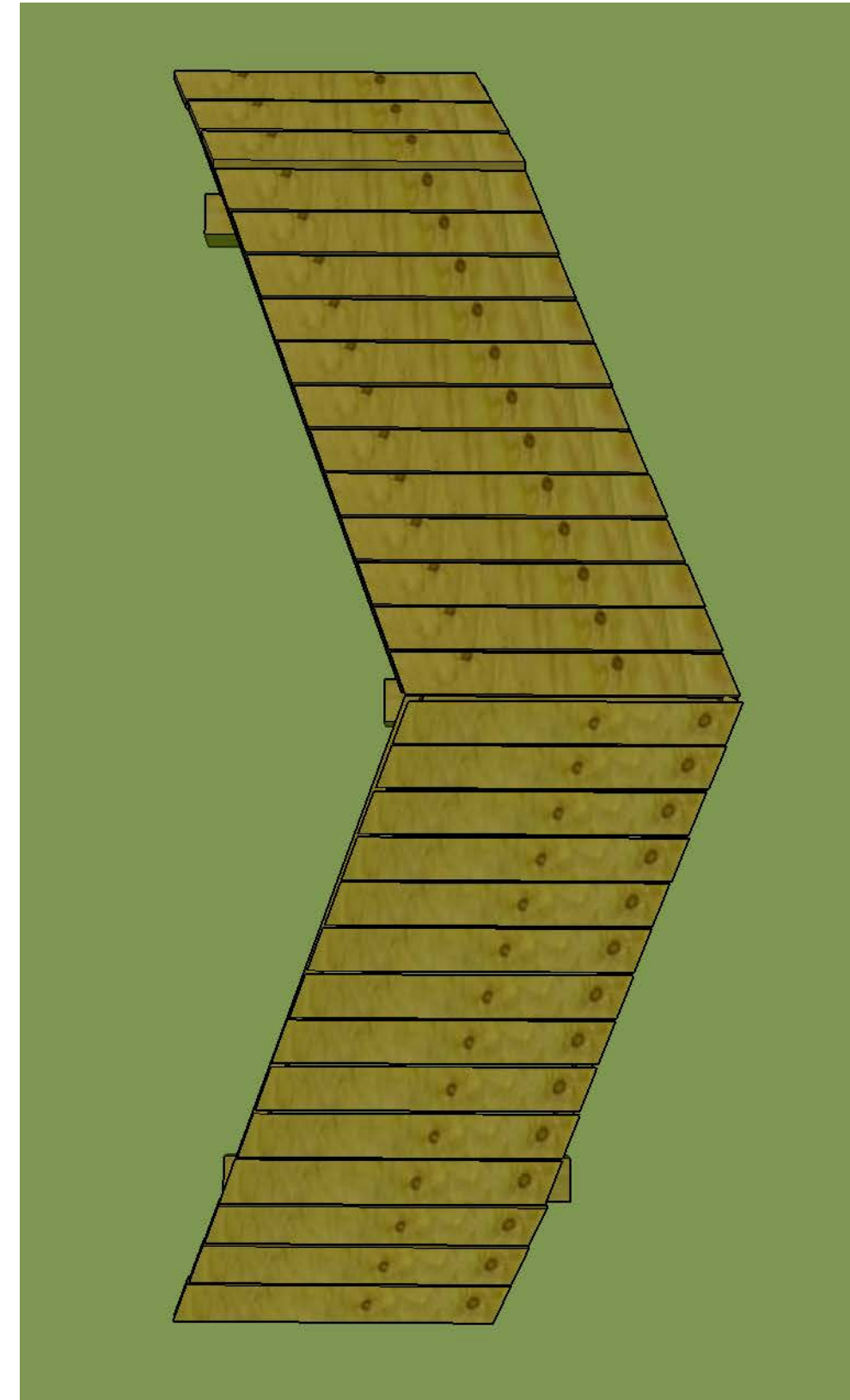

Bottom View

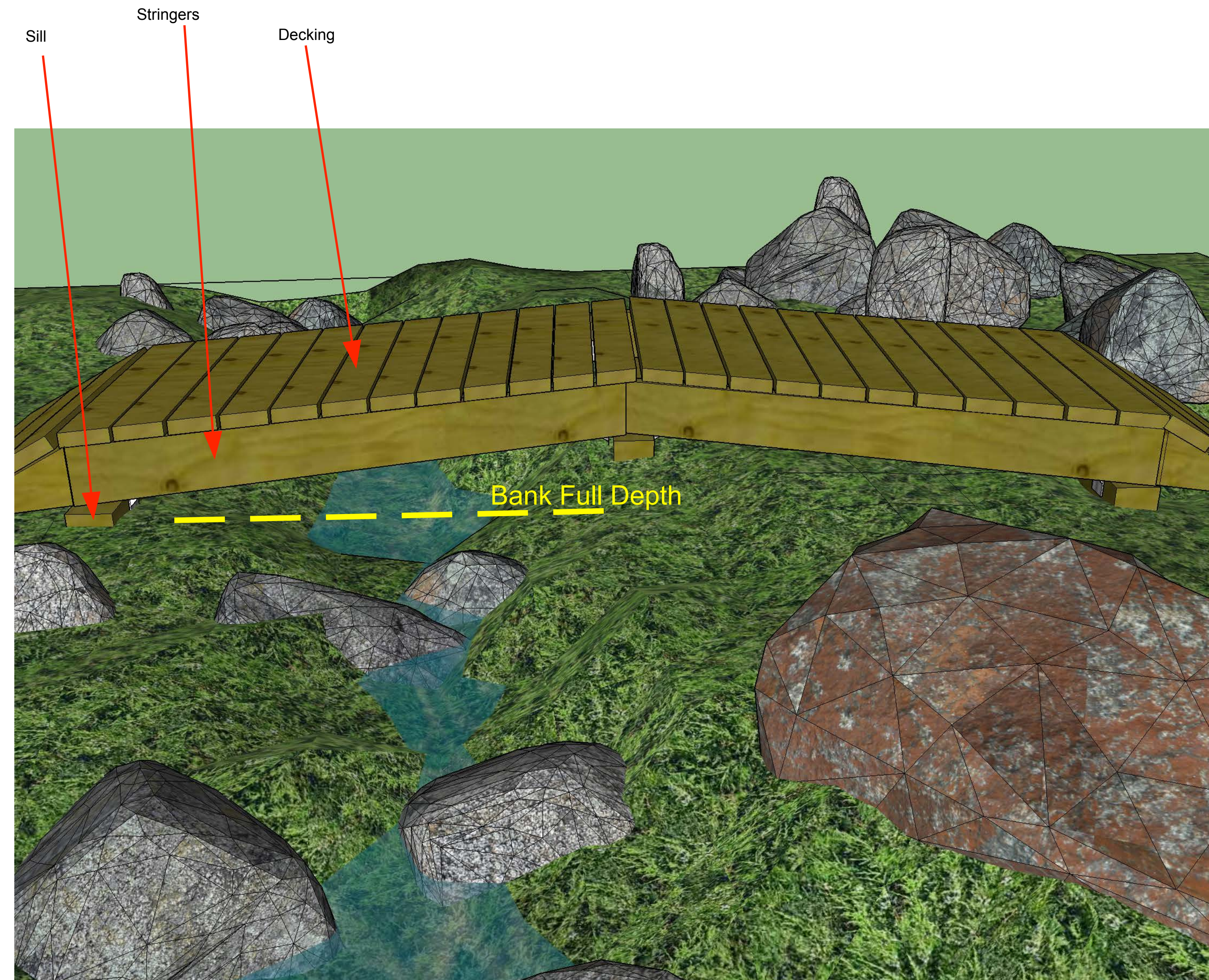
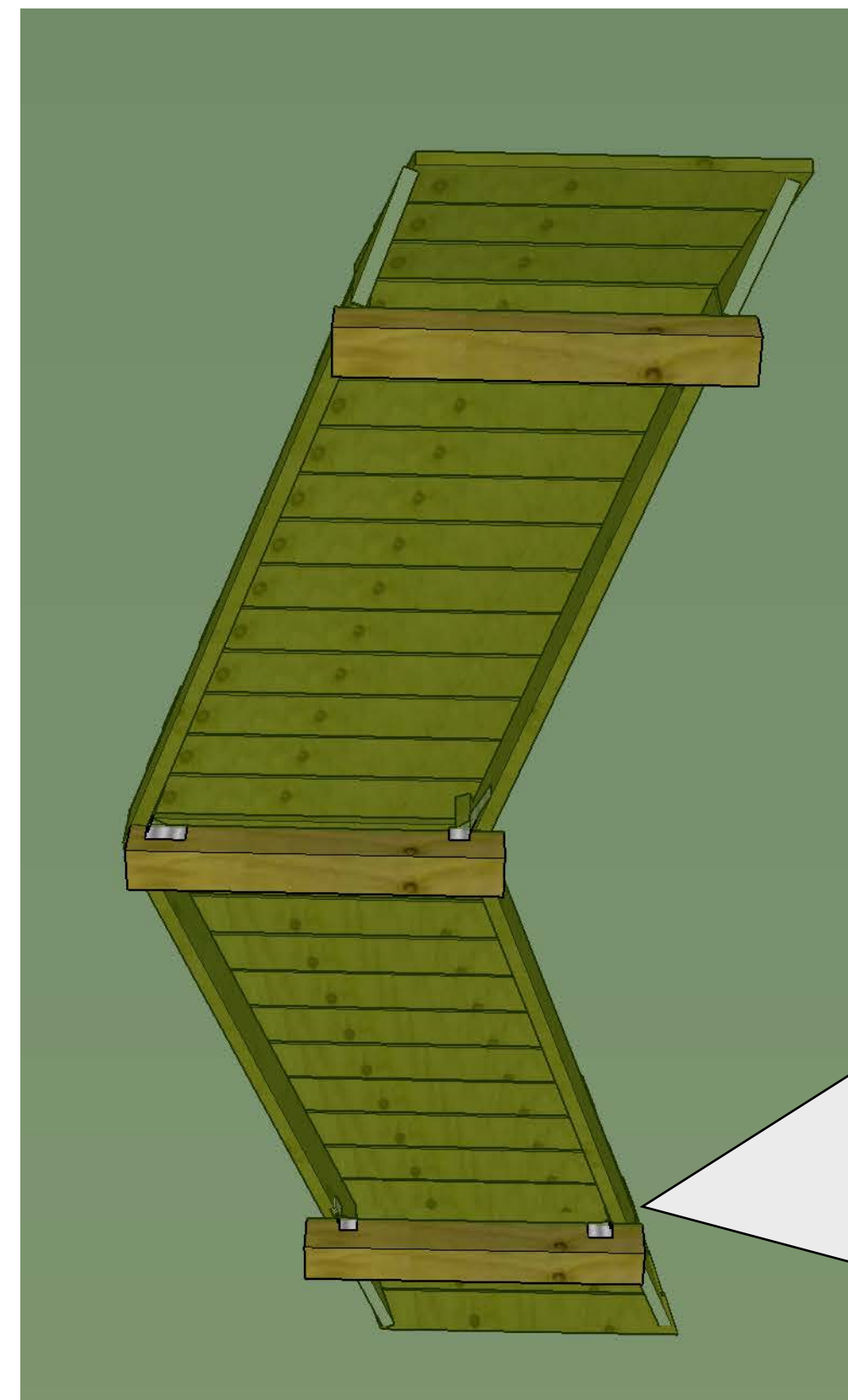

Figure 1.

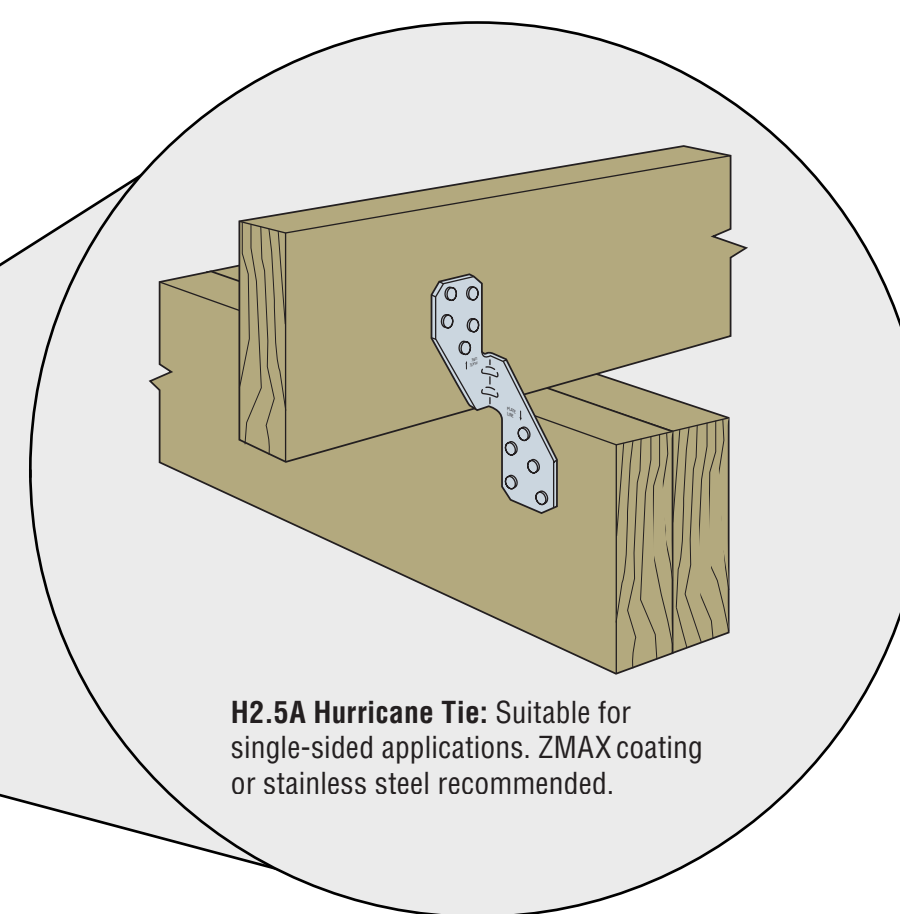
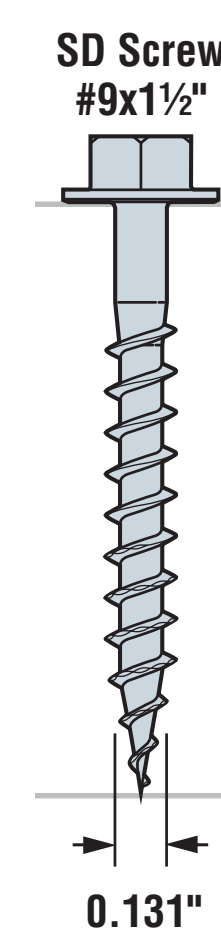
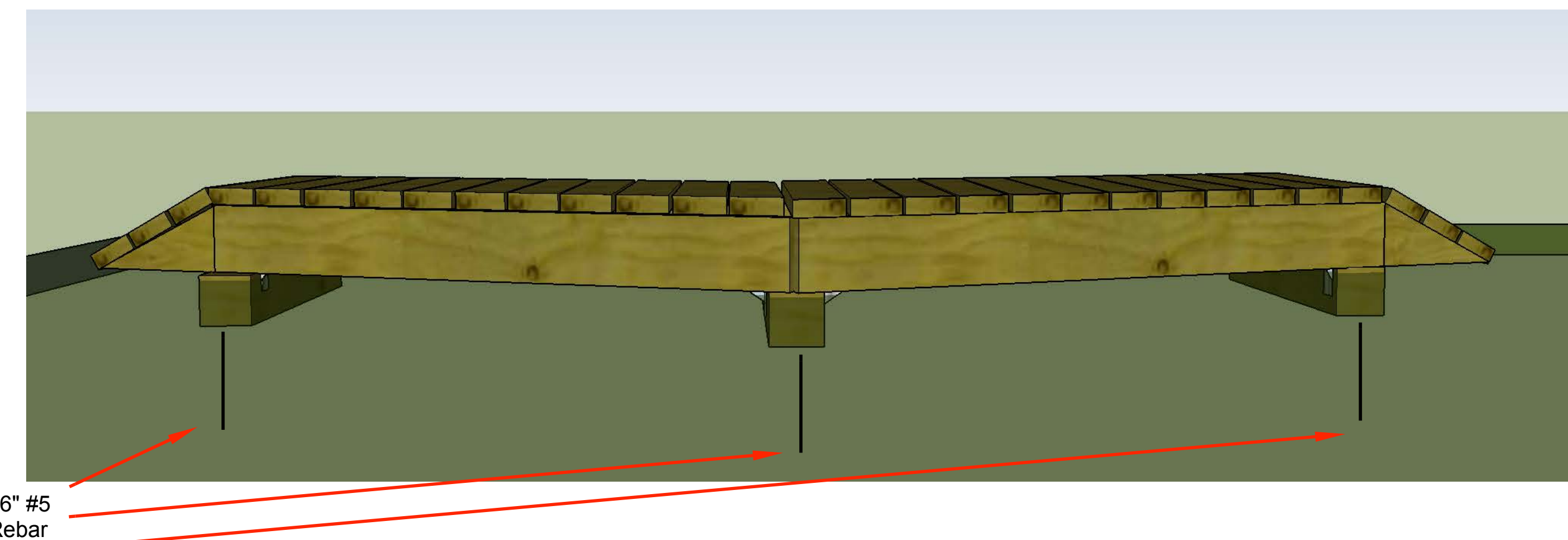

Figure 2.



Side View



Notes:

1. Bridges are specified for perennial streams with bed and bank structure equal to or deeper to 3 feet. Puncheons are specified for intermittent or lesser flowing streams. Construction process for bridges and puncheons are identical except for stringer size and footers. See notes 2, 4 and 5.
2. 6X6 ground contact sills, 1-2" above surrounding grade/height of potential flowing channel. 6" diameter 18" depth concrete footers for bridges greater than 18'.
3. 6x6 mud sills secured with 36" #5 rebar (~6" in from outside edge) and placed at locations above and lateral to channels or depressions.
4. Stringers will be set on 12" centers.
5. Stringers will be 2X10 for bridges less than 12'; 2X12 for bridges 12'-17'; Glulam 2X16 for bridges 18'-23'. All pressure treated. For bridges, cross-bracing on 6' centers.
6. Hardware to connect stringers to mud sills: Simpson Strong Tie Hurricane Clips (H2.5 AZ) (Figure 1.), Tie Plates (TP47), and #9 1.5" hex drive screws (SD9112MB) (Figure 2).
7. Decking is 2x6 rough cut durable hardwood or marine grade pressure treated, fastened with 3.5" decking screws and 30-degree 3" ring shank framing nails.
8. Edges of deck materials should not extend more than 3" from edge of stringers.
9. Fall zones cleared of woody and sharp debris 8' to all lateral surfaces of bridge.
10. Curvilinear construction of puncheon to blend with surrounding topography when possible.

Details 3. Flagstone Armored Crossing

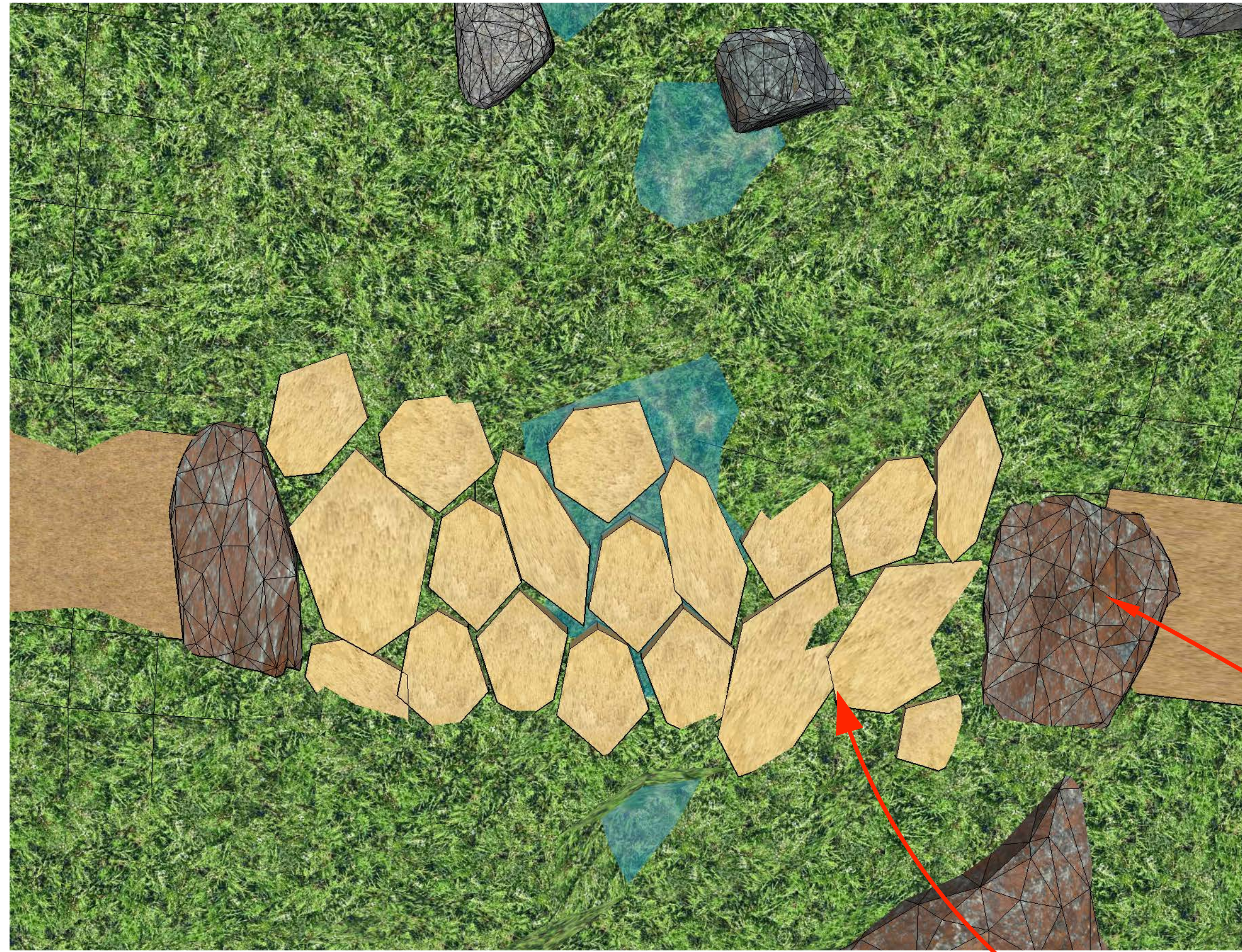

Anchor Stones

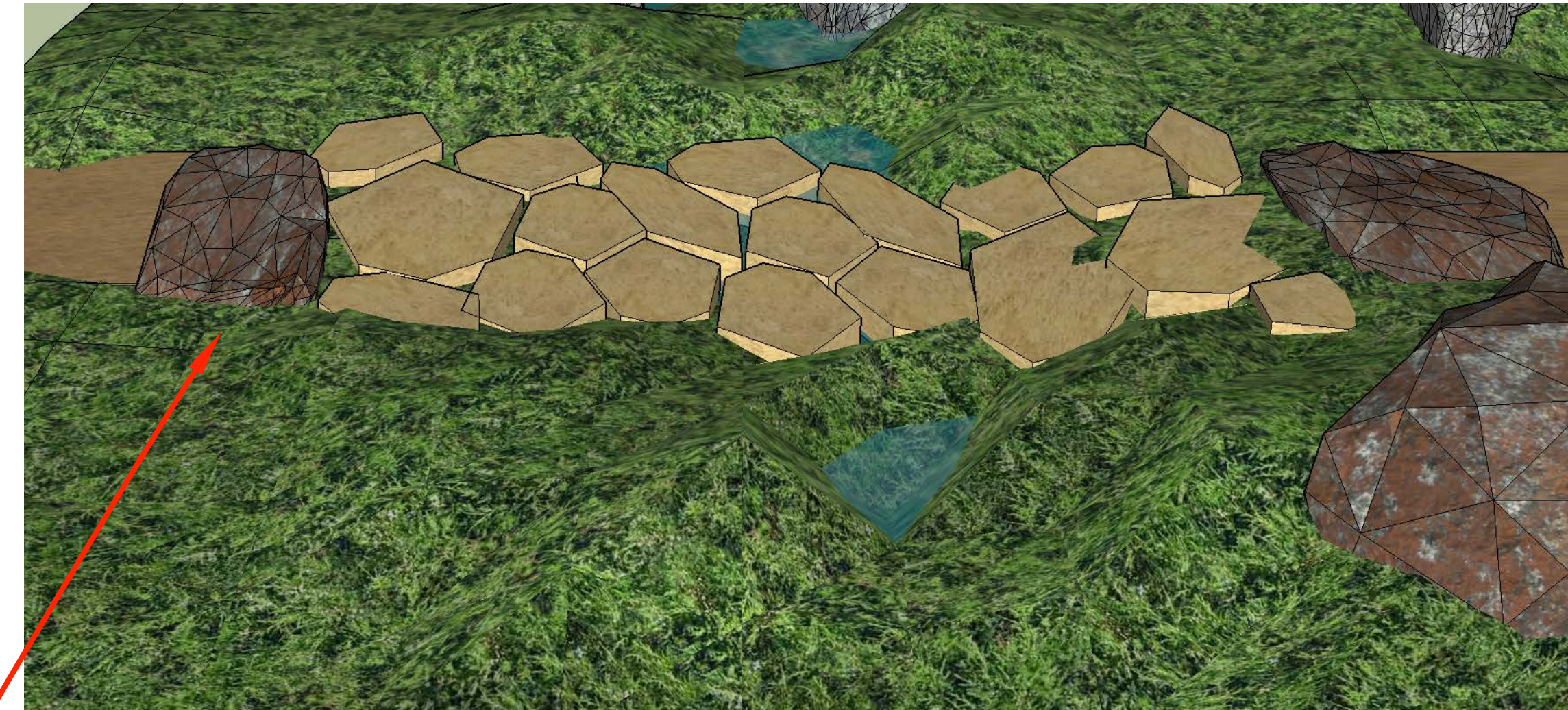

At Grade

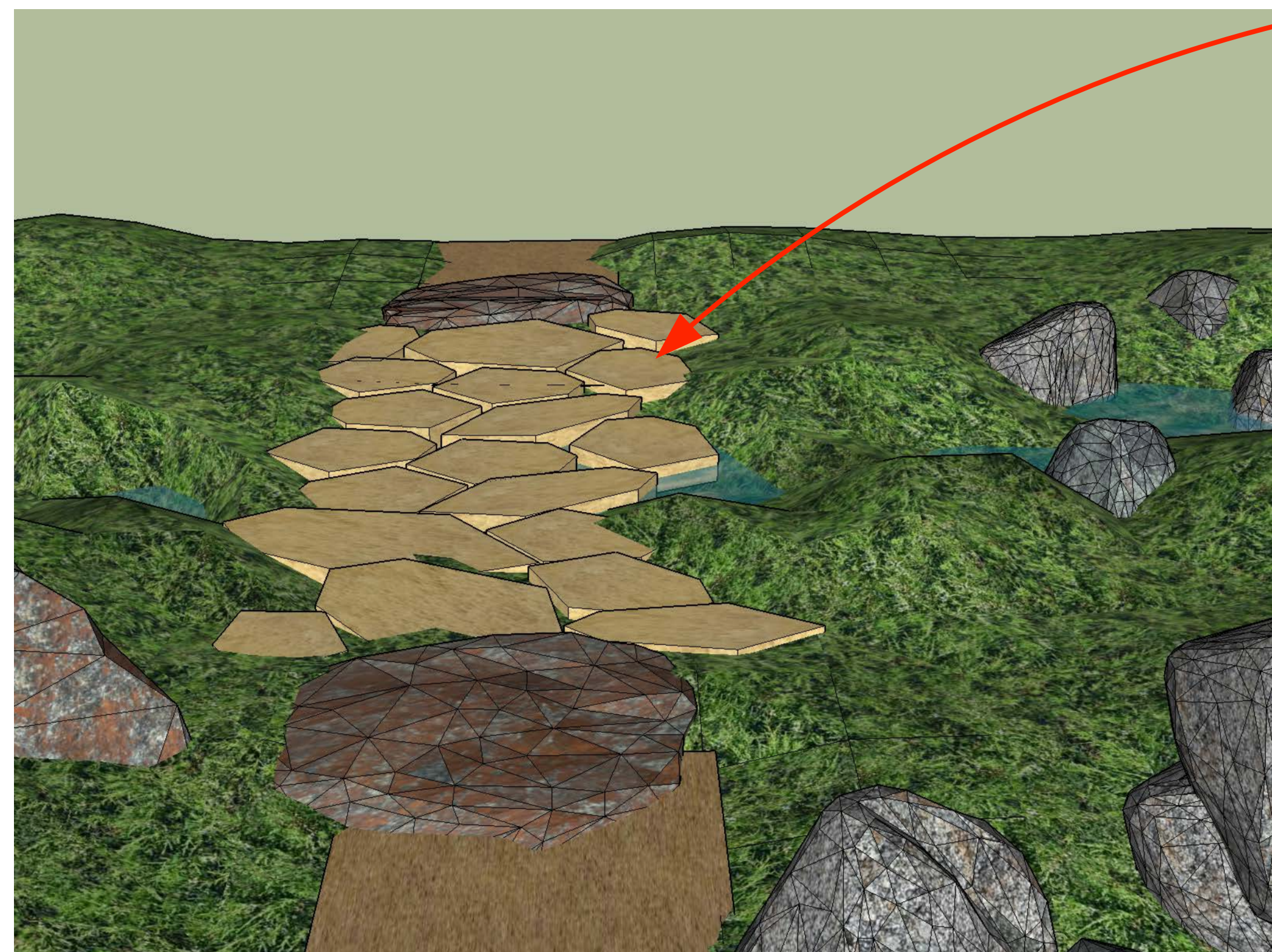

Notes:

1. Remove all organic matter from area of armoring to a depth of thickest rocks
2. Armoring to extend at least 6' beyond indications of surface flow or to extent of saturated soils.
3. Anchor Stones are placed at each terminus, span the entire trail tread and extend deep into the mineral soil (2/3 of rock must be buried).
4. Flagstones, large flat stones, are placed directly on mineral soil (or an aggregate foundation).
5. Flagstones are set at-grade to eliminate any potential obstruction to normal water flow.
6. Each stone must have 3 points of contact with other rocks and be locked into place.
7. Pore spaces between stones will be filled with smaller chock stones or crushed rock.
8. When complete, no rock in structure should move in any direction when significant pressure is applied.

Details 4. Stone Pitched Armored Crossing

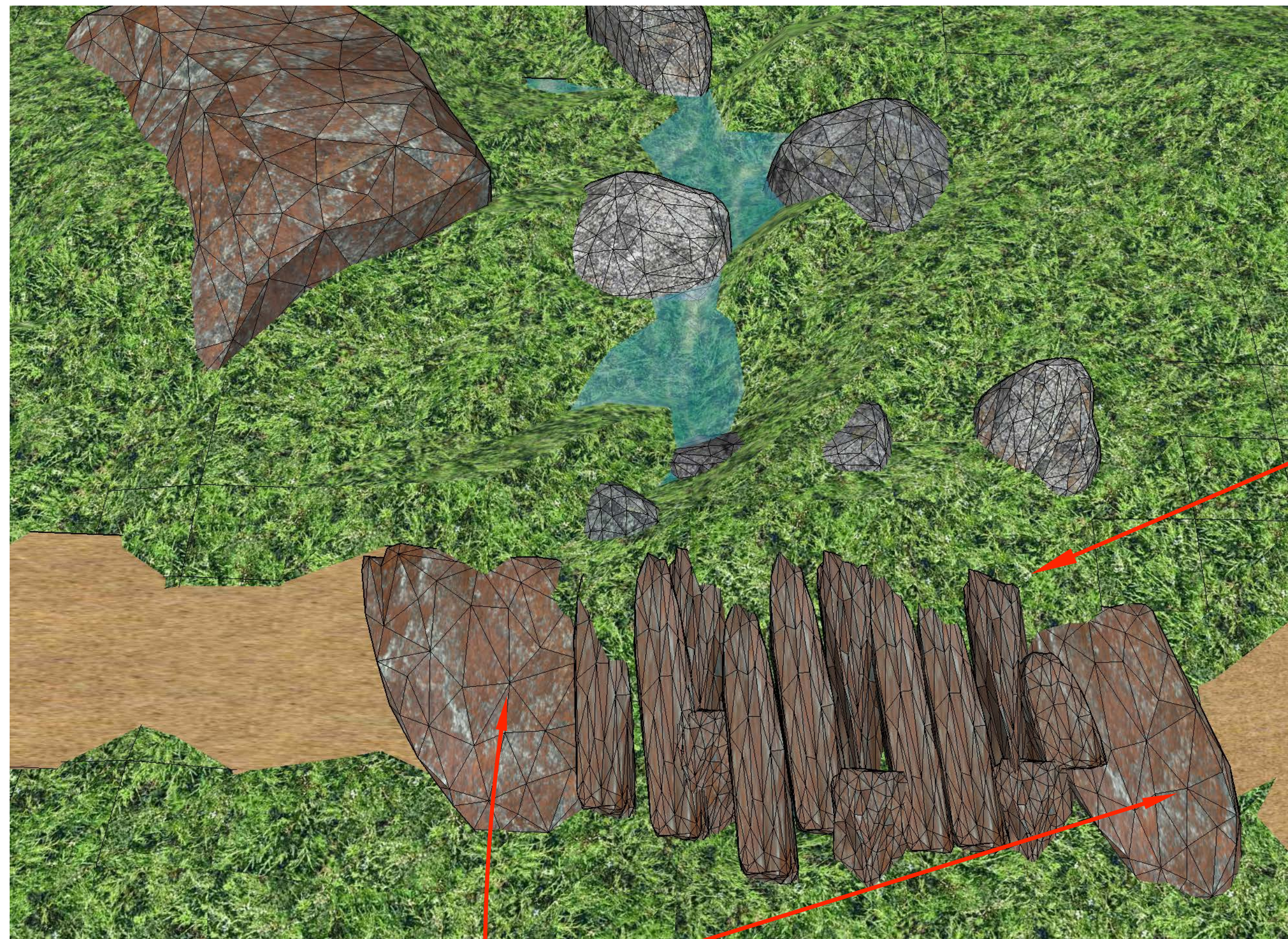

Anchor Stones

Chock Stones

Notes:

1. Remove all organic matter from area of armoring to a depth of thickest rocks.
2. Armoring should extend to a minimum of 6' past each edge normal high water surface or to extent of saturated soils.
3. Anchor Stones are placed at each terminus, span the entire trail tread and extend deep into the mineral soil (2/3 of rock must be buried).
3. Stones are placed at grade to eliminate any potential obstruction to normal water flow.
4. Stones pitched on end with majority of stone underground, placed directly on mineral soil (or an aggregate foundation).
7. Each stone must have three points of contact with other rocks to "lock" into place.
8. Chock Stones added last to increase structural stability. Pore spaces between stones will be filled with smaller chock stones or crushed rock.
9. When complete, structure should not move in any direction when significant pressure is applied.

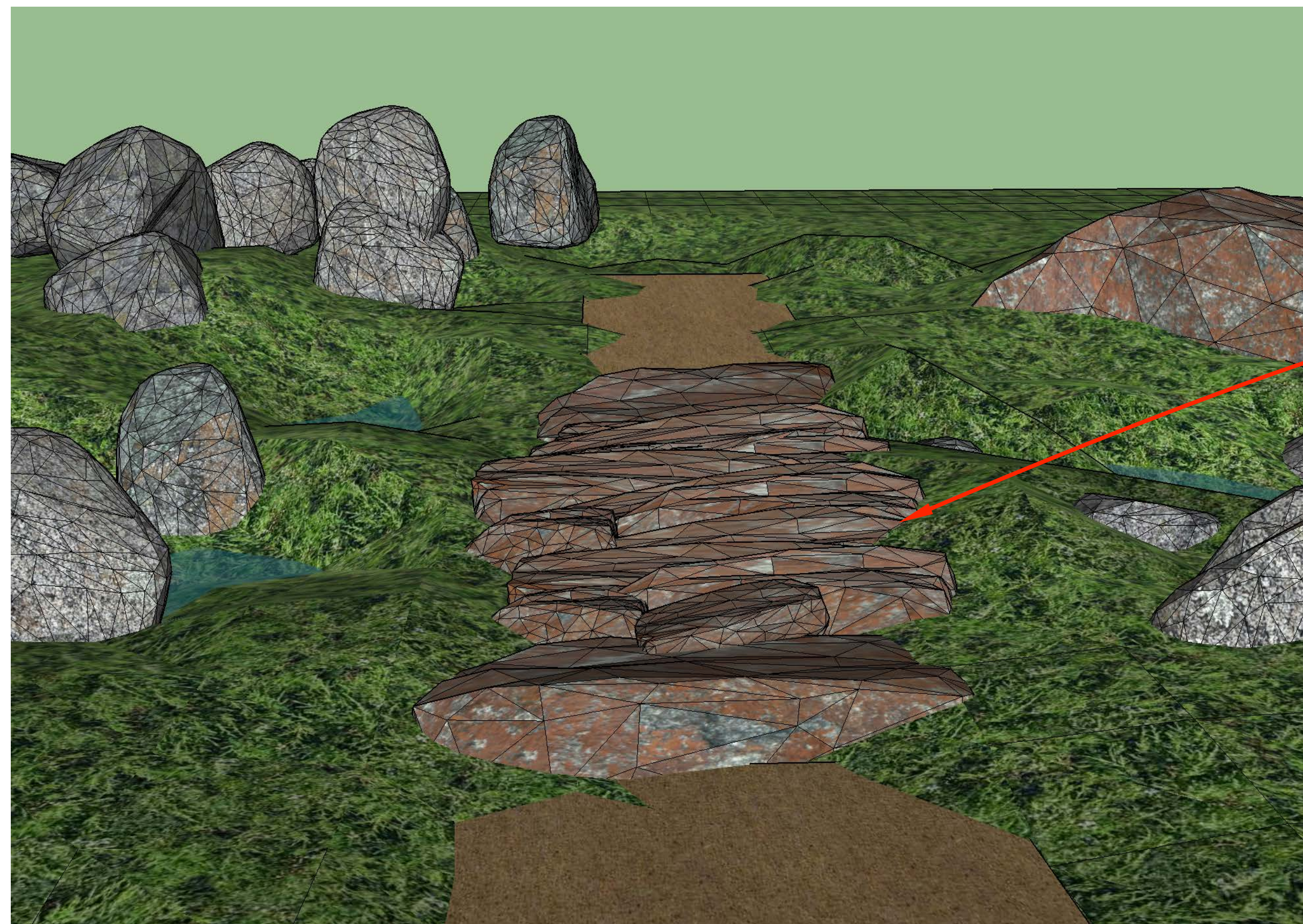

Rocks Placed At Grade

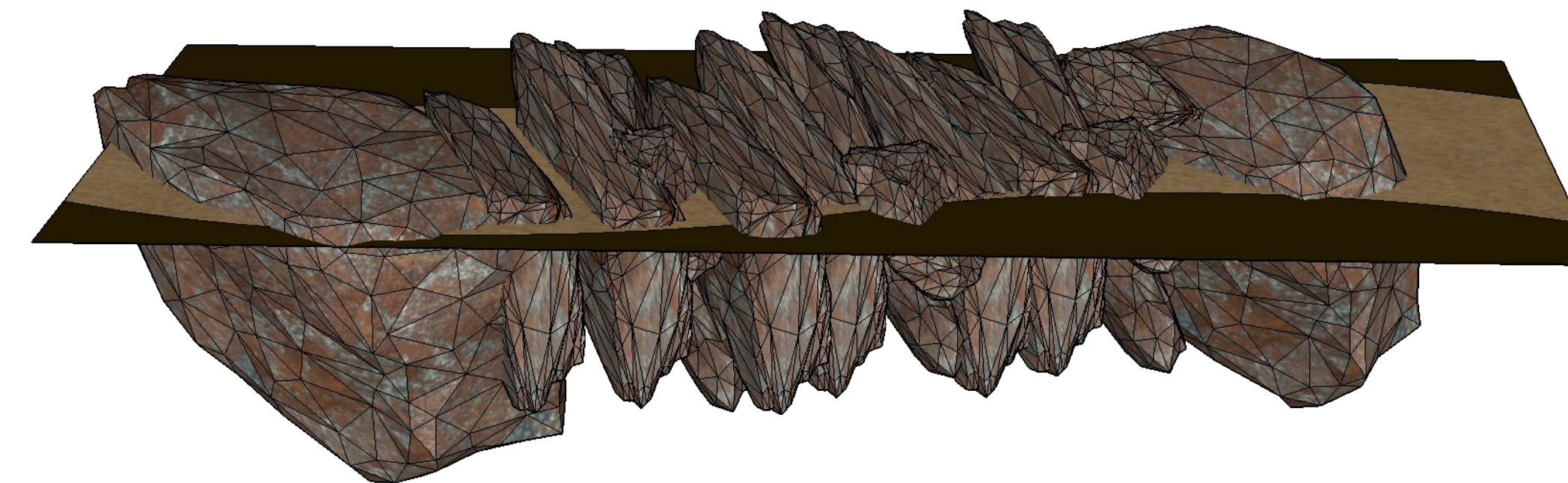

Majority of Rock Underground

Details 5. Arched Half Culvert

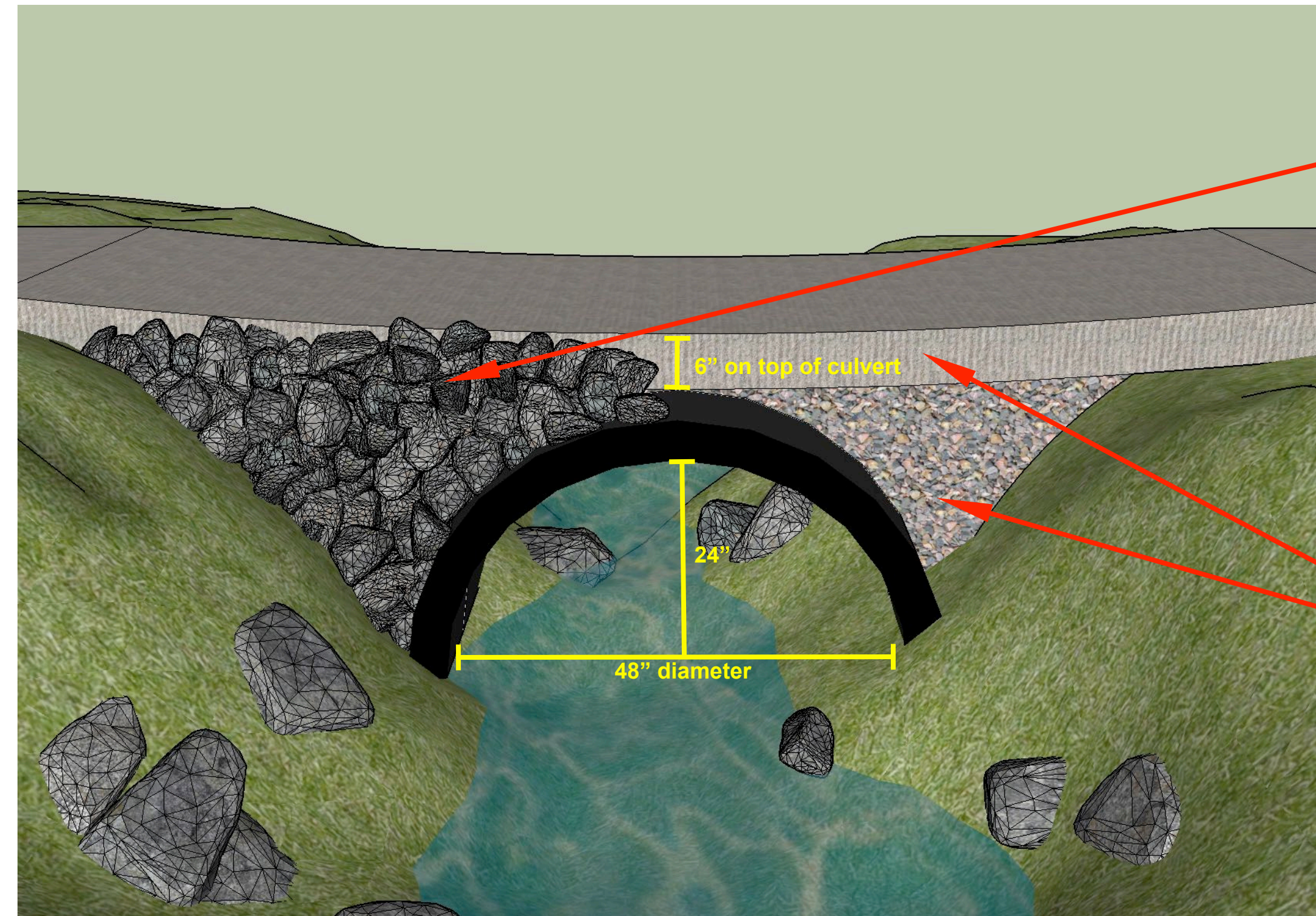

Rocks (or 1/2"-minus aggregate, if rock is not available) placed on exposed culvert inlet/outlet and blended from exposed edge of culvert to top of compacted fill material. Treatment should cover the entire culvert (only half treatment shown in diagrams).

Compacted dry mineral soil (or 1/2"-minus aggregate if suitable, dry mineral soil is not available)

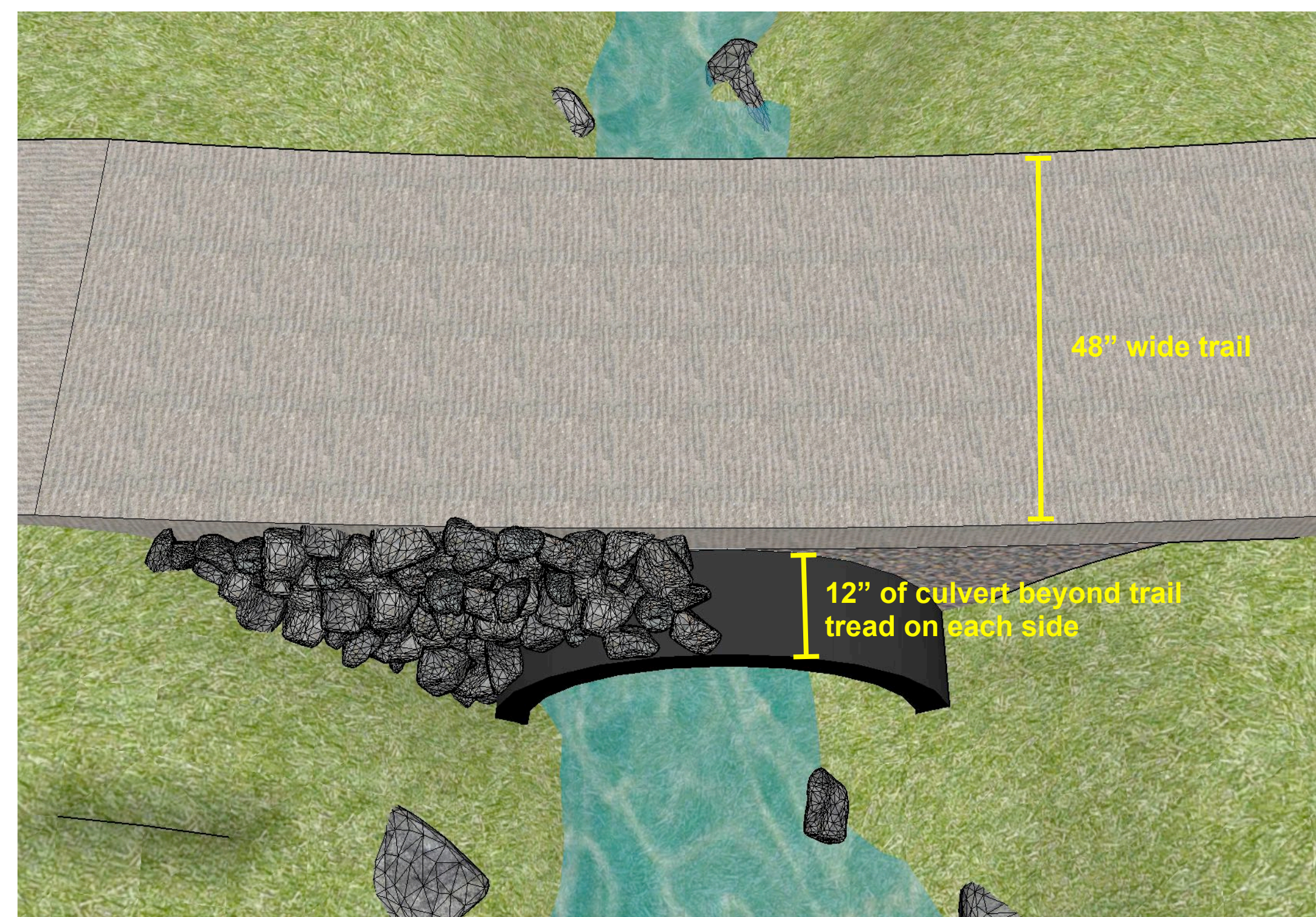
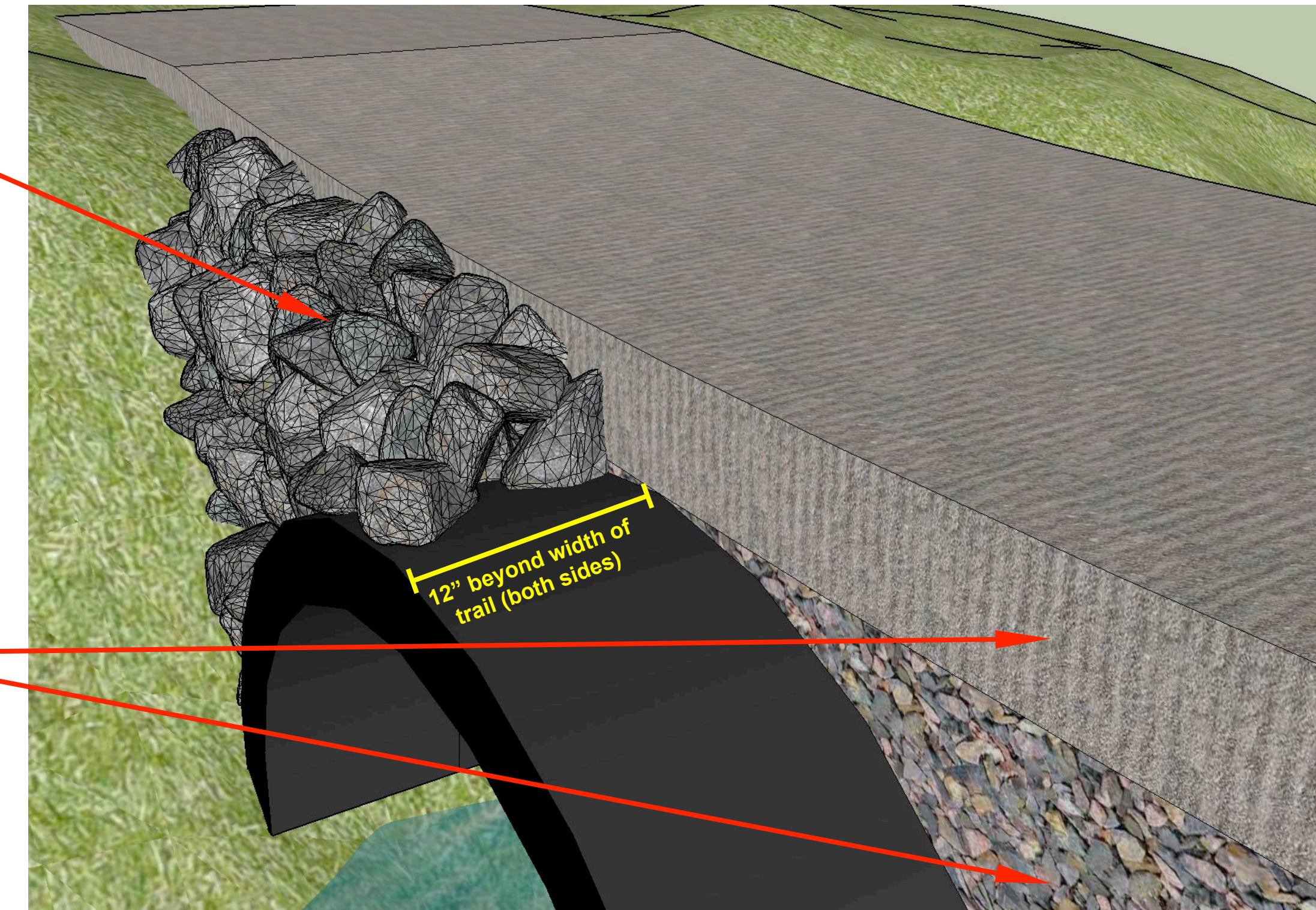

NOTES:

1. Ensure grade reversal within 25' of each side of culvert location.
2. Install any sediment and erosion control, as directed by permitting or local code, on each side of culvert location.
3. Final culvert location will be determined in the field, in association with construction manager.
4. Excavate stormwater conveyance channel to a width of 48" (or appropriate culvert diameter), if necessary, but do not excavate the active bed of the channel.
5. Cut full, HDPE, double walled, plastic culvert in half and to a length of 2' longer than the width of the trail, as described in the specifications.
6. Install culvert directly in line with channel flow and assure full ground contact along the entire length of the culvert on both sides.
7. Place and compact 6" of dry mineral soil (or 1/2"-minus aggregate if suitable, when dry mineral soil is not available) on top of the culvert and to the width of the trail, as described in the specifications, leaving 1' of exposed culvert on each side of the fill.
8. Place rock (or 1/2"-minus aggregate, if rock is not available) on exposed culvert inlet and outlet and blend from plastic edge of the culvert to the top of compacted fill material.

TRAIL MAINTENANCE AND ENHANCEMENTS AT THE BAILEYS TRAIL SYSTEM
REQUEST FOR QUOTES
ATHENS-WAYNE OUTDOOR ASSET DEVELOPMENT CORPORATION

ATTACHMENT B. FRONTCOUNTRY TRAIL SPECIFICATIONS

TRAIL TYPES

All-Weather Trails (0.7 miles, 1% of total mileage)

Short trail loops with a rock aggregate surface (yellow on maps), connected directly to trailhead parking will provide access to the forest for all visitors. The distance and smooth surface will provide for the use of strollers and push bikes without muddy conditions, even during seasonally wet conditions. Developed at a width that allows for users to pass comfortably, these introductory trails may also have adjacent interpretive information or beginner riding skill development features.



Frontcountry Trails (16.8 miles, 19% of total mileage)

Shorter distance/duration loops that cater to visitors with lower levels of trail experience, stamina, or time will be accessed directly from the trailheads. These beginner-friendly trails (green on maps) will be constructed to a width that allows trail users to safely pass without getting off the tread of the trail. The trail tread will be constructed to be primarily smooth to provide maximum accessibility to a variety of trail users, including adaptive or hand-propelled bicycles. Biking skills development features may be present, but will be placed adjacent to the trail and developed to be “rollable” and not require advanced balance or strength to negotiate.



Backcountry Trails (70.1 miles, 80% of total mileage)

Multiple options will extend from the frontcountry trails to provide longer distance/duration loops. These intermediate (51.6 miles, blue on maps) and advanced (18.5 miles, red on maps) level trails allow visitors with higher levels of fitness and/or time extend their exploration of the forest. The trail widths will be relatively narrow and passage will require a trail user to step to the side of the trail to accommodate passage. Trail grades and distances of climbs/descents will increase on these backcountry trails. The most difficult trails will be optimized for mountain biking and may have a downhill directional orientation. The trail surface will be heavily textured with larger rocks and roots exposed in the tread. Challenging riding features may be present within or adjacent to the main trail tread, constructed of natural materials, which may require advanced balance or strength to negotiate, and could provide the opportunity to jump.



SPECIFICATIONS

Trail Type Name: Frontcountry- Natural Surface

Difficulty Rating: Easy to Moderate

Difficulty Symbol: Blue Square

USFS Trail Class: 3

Designed Use: Mountain bike

Managed Uses: Mountain bike, pedestrian

Typical Tread Width: 36"-50"

Typical Corridor Width: 48"-60"

Tread Rugosity: Relatively smooth, some roots or rocks, protrusions <3" above trail tread

Average Gradient: <8%

Maximum Sustained Grade: 12%

Maximum Grade: 15% with surface treatment

Typical Tread Materials: Natural surface with surfacing amendments where necessary

Sideslope Steepness: Flat to 75%

Turn Radius: Wide and open

Trail/Structure Formality: Formal, 48" width

Wet Area Crossing Formality: Formal bridges for minor/major crossings, 60" minimum width

Duty of Care: Moderate

Intended Experience: The frontcountry trail should provide a well-defined tread with constantly reversing grade and moderate, short climbs and descents. Excavated soil material may be utilized to form rollers, insloped trail segments on outside turns, and superelevated turns to enhance the riding experience. The trail tread may include avoidable obstructions/constructed features that can be easily rolled over without advanced bike handling skills. Alternate, more challenging riding features may be constructed outside the direct riding path.

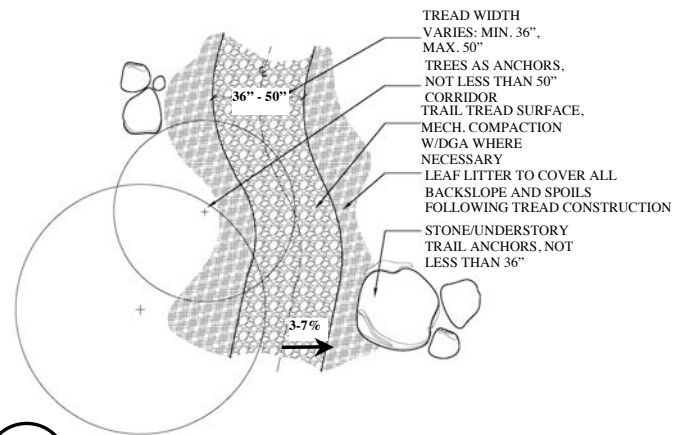

2.1

N.T.S

PLAN DETAIL: FRONTCOUNTRY TRAIL- TYP.

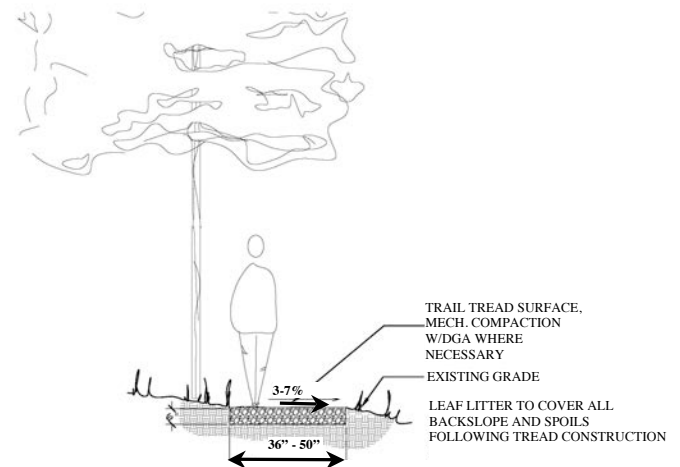

2.2

N.T.S

SECTION DETAIL: FRONTCOUNTRY TRAIL- TYP.



TRAIL MAINTENANCE AND ENHANCEMENTS AT THE BAILEYS TRAIL SYSTEM
REQUEST FOR QUOTES
ATHENS-WAYNE OUTDOOR ASSET DEVELOPMENT CORPORATION

ATTACHMENT C. ADAPTIVE MOUNTAIN BIKE TRAIL SPECIFICATIONS



KOOTENAY ADAPTIVE SPORT ASSOCIATION

ADAPTIVE TRAIL STANDARDS - 2020



KOOTENAY ADAPTIVE SPORT ASSOCIATION

409 Broadway St W
Nakusp, BC
VOG 1R0

☎ 250-265-3868

✉ info@kootenayadaptive.com

ACKNOWLEDGMENTS

KASA MANDATE: To promote physical literacy and elevate the human spirit through facilitated learning experiences in a barrier free environment. To advocate and educate in support of adaptive sport and recreation by providing resources, organizing events and programs, and building a safe and inclusive community.

The Kootenay Adaptive Sport Association would like to thank the following organizations and individuals for their contributions to the assembly of these Adaptive Trail Standards:

KOOTENAY ADAPTIVE SPORT ASSOCIATION

Janis Neufeld - Senior Project Manager
Mike Riediger - Executive Director
Kimberly Joines - 2020 Accessibility Supervisor
Wynn Holmberg - 2020 Accessibility Coordinator

ADAPTIVE RIDERS

Kimberly Joines - Athlete
Tara Llanes - Tara Llanes Industries , Athlete
Ethan Krueger - Athlete

LARCH LANDSCAPE ARCHITECTURE

Jason Jones - Landscape Architect, Trail Designer

STARR TRAIL SOLUTIONS

Brady Starr - Trail Designer, Trail Builder

TRAIL HOLISTICS

Mark Wood - Trail Designer

LIFETIME OUTDOORS

Jeff Cook - Trail Designer, Trail Builder

Tara Llanes - Tara Llanes Industries - Athlete

Kimberly Joines - Athlete

Ethan Krueger - Athlete



LARCH LANDSCAPE ARCHITECTURE

Jason Jones - Landscape Architect, Trail Designer

STARR TRAIL SOLUTIONS

Brady Starr - Trail Designer, Trail Builder

TRAIL HOLISTICS

Mark Wood - Trail Designer

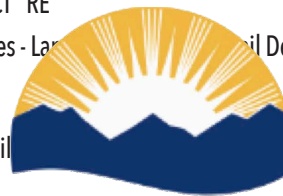

BRITISH COLUMBIA

This program is funded by the Government of Canada
and the Province of British Columbia.

LIFETIME OUTDOORS

Jeff Cook - Trail Designer, Trail Builder

ADAPTIVE MOUNTAIN BIKES AND DIFFERENTIATING FACTORS

Adaptive Mountain Bikes (aMTB): Adaptive Mountain bikes are three and four wheeled cycles that provide a broad range of riders who may not otherwise ride a standard mountain bike due to physical, intellectual, neurological and sensory abilities. The Kootenay Adaptive Sport Association (KASA) has developed a comprehensive set of trail standards to assist in the planning, design, and construction of safe and fun adaptive mountain bike trails based on the following:

- Adaptive mountain bikes accelerate slower, decelerate faster, are wider, longer and heavier than two wheeled bikes;
- Some models require the rider to take their hand(s) off the handlebars in order to pedal with the hand cranks. As such, a aMTB rider cannot easily pedal while navigating a turn, and requires appropriate (trail specific) entry speed to corners, berms and features to allow enough momentum to carry the bike through;
- Sight lines for adaptive riders are approximately 1.0m (3 ft) above the tread surface. This requires consideration in trail sections of significant undulation, high vegetation, intersections, etc.; and
- Adaptive mountain bikes are primarily 3-wheeled in nature, and prone to tipping when off-camber at low speeds. aMTB riders will be strapped into their equipment, so any tipping of the bike will also tip the rider, which can be dangerous.

Hazards + Ride Arouns: The most pressing consequence for aMTB is tipping over in areas of exposure, which could result in aMTB (and rider) rolling down an embankment. This also is applicable to raised, off-camber features. It is recommended to provide a less consequential fall zone below any such feature and aMTB tread width ride-arounds for any feature requiring a specific skill set or for momentum to clear (i.e. gap jumps, non-rollable jumps with large lips), narrow wooden stunts, or off-camber raised features.

RECOMMENDED TRAIL WIDTH

The majority of aMTB equipment require a minimum 1.0m (40") width for chokes, pinches and a minimum 1.2m (48") tread width required for general riding performance. [Figure 1](#) and [Figure 2](#) indicate general aMTB trail width recommendations based on difficulty rating. Refer to [Appendix A: Trail Difficulty Rating System](#).

CAMBER

Traversing off-camber terrain can be difficult on aMTB. The following guidelines pertain to off-camber trail construction:

- Bench cut trail should be firm and compacted to full trail tread width with out-sloping at minimal angle as required for drainage (3-5% slope, 1.25-2.85 degrees). Less out-sloping is preferred;
- Confirm there will be adequate speed to carry aMTB through off-camber trail section exceeding 8% slope (5 degrees) *Momentum reduces tipping hazard;
- Eliminate off-camber or one-sided TTF/obstacles exceeding 12% Slope (8 degree camber angle), or provide full aMTB tread width ride-around
- (Refer to [Figure 3](#) and [Appendix A: aMTB Trail Difficulty Rating System](#) - Obstacles to match spec to trail difficulty); and
- Gradually transition off-camber trail features (returning to minimum cross slope), to allow pedal stroke before onset of next feature or trail section.

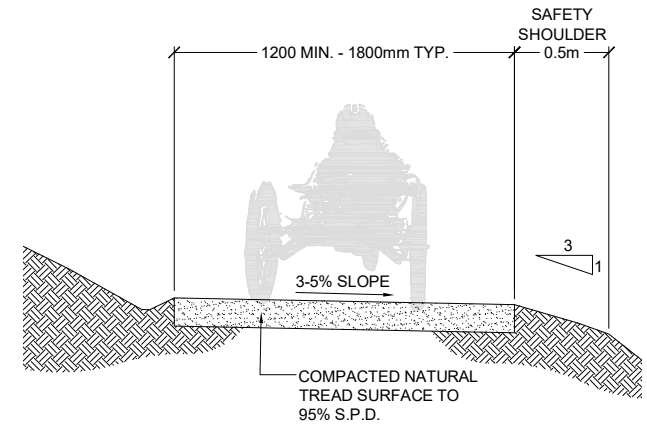

[Figure 1 - Typical aMTB Trail Section](#)

RECOMMENDED aMTB TRAIL WIDTH		
GREEN	BLUE	BLACK
1.80 m 6 ft 72 in	1.50 m 5 ft 60 in	1.20 m 4 ft 48 in

[Figure 2 - Recommended aMTB Trail Width](#)

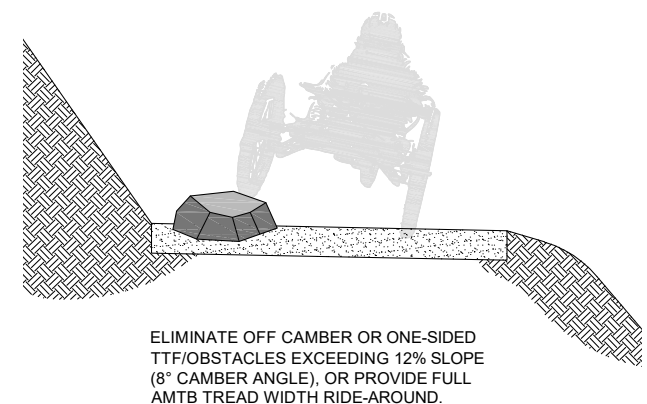

[Figure 3 - Off-Camber Hazard](#)

CORNERS | BANKS | BERMS

Speed:

- If entry speed is too slow in relation to the bank gradient, the rider will be drawn into the drainage/low point of berm, and risk tipping inward;
- Corners need to accommodate the physical aspects of the aMTB bike (rolling resistance, weight) throughout the radius to ensure acceleration through the corner; centrifugal force maintains the aMTB's position on the bank; and
- aMTB cannot easily be pedaled mid turn; berm exit needs to be lower than the entry (Refer to [Figure 4](#)).

Radius:

- The ideal radius range for aMTB corners is 6-7.5m (20-25 ft) as berm size and trail speed increases, tighter radii can be achieved; and
- Any radius less than 4.6m (15ft) will require higher level of rider ability, and/or result in 2-point turns (Refer to [Figure 4](#)).

Shape:

- A linear banked berm shape is preferred over "Concave" or "Scooped" berm design. Linear berms present less risk of tipping. Applicable to full width/large berms. Ensure that aMTB is able to achieve support on all wheels throughout the banked turn;
- The bank height and angle need to accommodate the ride speed, increasing with the rider's momentum throughout the radius of the corner, to a maximum slope of 60% slope (30 degree slope angle); and
- Due to the limited riding dynamics and turn radius of aMTB equipment, flat and outsloping corners should be avoided when possible during ascending and descending. Banked corners allow physics to help the aMTB complete the turn faster when descending. Small berms and extra material on the outside of climbing turns (even to partial thread width) can help aMTB achieve tighter turning radius, reducing the need for 2-point turns on switchbacks (Refer to [Figure 5](#)).

Grade Reversals:

- Drainage Deflection - Any grade reversal at the entry/exit points of a berm must be symmetrical within the trail tread (uniformly span the entire trail width at the same height) and set back far enough that the rider has adequate time to "set up" when entering/exiting the berm; and
- Grade reversals should not slow the aMTB rider enough to necessitate additional pedaling before exiting the corner.

Rollers:

- Roller spacing and height to be determined onsite based on anticipated rider speed. aMTB are longer than standard bikes, requiring longer spacing of rollers to ensure rear wheel and front wheels of the bike are not being forced in opposing directions simultaneously;
- Ensure rollers are gradual rather than abrupt, in profile; and
- Use cascading rollers to ensure rider can obtain momentum to carry over the flat and uphill portion of roller without pedaling (Refer to [Figure 6](#)).

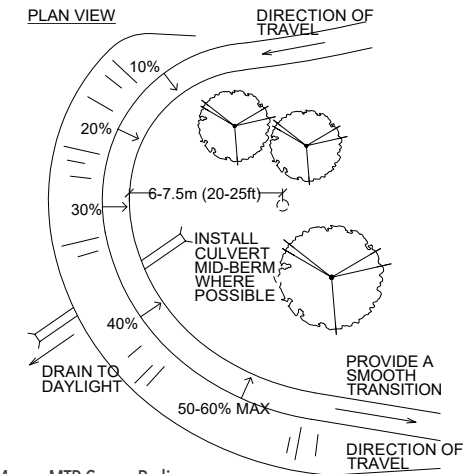

Figure 4 - aMTB Corner Radius

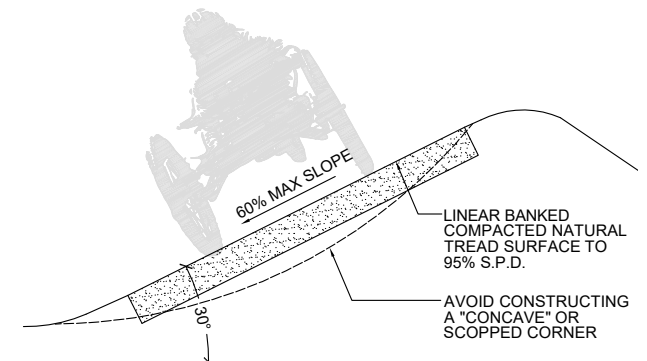

Figure 5 - aMTB Berm

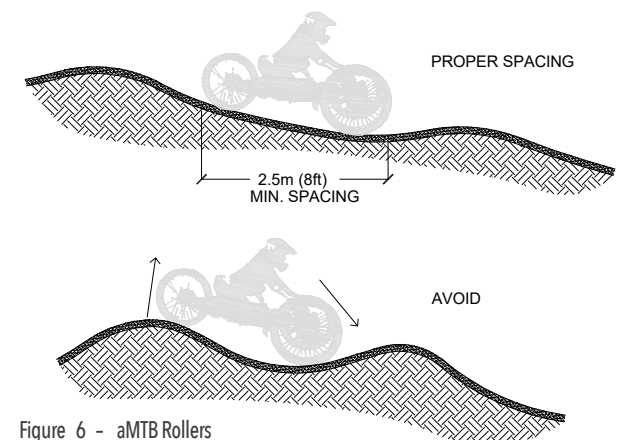

Figure 6 - aMTB Rollers

APPENDIX A - ADAPTIVE MOUNTAIN BIKING (AMTB) TRAIL DIFFICULTY RATING SYSTEM

	aMTB WHITE	aMTB GREEN	aMTB GREEN SQUARE	aMTB BLUE	aMTB BLACK	aMTB DBL BLK	aMTB DBL. BLK
TRAIL WIDTH: (ave/min)	1.8m+ (72"+)	1.8m/1.5m (72"/60")	1.7m/1.4m (66"/54")	1.5m/1.2/ (60"/48"+)	1.2m/1m (48"/40")	1.1m/0.98 m (44"/38.5")	<0.98m (<38.5")
TREAD SURFACE:	hardened or surfaced	firm and stable	mostly stable some variability	mostly stable some variability	widely variable	widely variable and unpredictable	widely variable and unpredictable
OBSTACLES (TTF):	no obstacles	obstacles full width 2" or less / no asymmetrical tread areas	obstacles full width 5" or less / partial width 2" or less	obstacles full width 8" or less / partial width 3" or less	obstacles full width 12" or less / partial width 6" or less	obstacles full width 12" or less / partial width 10" or less / assistance recommended	impassable obstacles / assistance required
UNAVOIDABLE BRIDGES: (wider if not straight)	1.8m+ (72"+)	1.5m+ (60"+)	1.5m+ (60"+)	1.4m+ (54"+)	1.2m+ (48"+)	1m+ (40"+)	<0.98m (<38.5") possible
MAX TRAIL GRADE:	10% (6 deg)	15% (8.5 deg)	20%+ (11 deg)	20%+ (11 deg)	20%+ (11 deg)	25%+ (14 deg)	25%+ (14 deg)
CAMBER: TURNS, BERM & TTF	level	only enough to drain	Some off camber possible: max 36.5% (20 deg)	Some off camber possible: max 36.5% (20 deg)	Some off camber likely: max 58% (30 deg)	Off camber certain: 58%+ possible (>30 deg)	Off camber certain: 58%+ possible (>30 deg)
CAMBER: TRAIL STRAIGHTAWAYS	level	only enough to drain	max outslope 5-8% (3-5 deg)	max outslope 5-8% (3-5 deg)	max outslope 8-14% (5-8 deg)	max outslope 8-14 % (5-8 deg)	14%+ (> 8 deg) outsloping possible
MIN FLAT CORNER RADIUS:	7.5m (24.5 ft)	6m (20 ft)	6m (20 ft)	6m (20 ft)	6m (20 ft)	4.5m (15 ft)	4m (13 ft)
MIN BERM CORNER RADUS:	n/a	n/a	6m (20 ft)	4.5m (15 ft)	4.5m (15 ft)	<4m (13 ft)	< 3m (10 ft)
EXPOSURE:	no exposure	no exposure	no exposure	minimal exposure	exposure likely	exposure likely	exposure likely
RECOMMENDED EQUIPMENT:							
<small>*Riders may choose to take equipment on trails falling outside of recommended trail difficulty at their own risk, but in this case support rider always recommended. !</small>							

RECOMMENDED EQUIPMENT / CATEGORY DESCRIPTIONS (LEGEND)

WHEELCHAIR:

- Manual wheelchair (with or without front wheel attachment)
- Powerchair
- Scooter
- Any other mobility related device



CROSS-COUNTRY (RECUMBENT / COMBINED CRANK & STEERING):

- **One wheel in the front** and two in the back
- Front wheel drive
- Seating – recumbent type seating with legs straight ahead
- Full or no suspension depending on brand



ALL-MOUNTAIN (RECUMBENT / COMBINED CRANK & STEERING):

- **Two wheels in the front** and one wheel in the back
- Rear wheel drive
- Seating – recumbent type seating with legs straight ahead
- Full suspension or rear suspension only depending on brand



ALL-MOUNTAIN (KNEELING / HANDLEBARS W/ SEPARATE CRANK):

- Two wheels in the front and one wheel in the back
- Rear wheel drive
- Seating – kneeling with cranks below you and handlebar above
- Full suspension or rear suspension only depending on brand



BOWHEAD ALL ELECTRIC

- Two wheels in the front and one wheel in the back
- Articulating front end
- Full electric with hand twist throttle; no crank; Rear wheel drive
- Seating – recumbent type seating with legs straight ahead
- Full Suspension



TRAIL MAINTENANCE AND ENHANCEMENTS AT THE BAILEYS TRAIL SYSTEM
REQUEST FOR QUOTES
ATHENS-WAYNE OUTDOOR ASSET DEVELOPMENT CORPORATION

**ATTACHMENT D. CLEAN AIR AND
FEDERAL WATER POLLUTION
CONTROL ACT**

ATTACHMENT D

CLEAN AIR ACT AND FEDERAL WATER POLLUTION CONTROL ACT

The contractor agrees to comply with federal clean air and water standards during the performance of this contract and specifically agrees to do the following:

- a. The term "facility" means (a) any building, plant, installation, structure, mine, vessel or other floating craft, location or site of operations (b) owned, leased or supervised (c) by the contractor and subcontractor (d) for the construction, supply and service contracts entered into by the contractor;
- b. That any facility to be utilized in the accomplishment of this contract becomes listed on the EPA list, this contract may be canceled, terminated or suspended in whole or in part;
- c. That in the event a facility utilized in the accomplishment of this contract becomes listed on the EPA list, this contract may be canceled, terminated or suspended in whole or in part;
- d. That it will comply with all the requirements of Section 114 of the Air Act and Section 308 of the Water Act relating to inspection, monitoring, entry, reports, and information, as well as all other requirements specified in Section 114 and Section 308, respectively, and all regulations and guidelines issued thereunder;
- e. That it will promptly notify the government of the receipt of any notice from the Director, Office of Federal Activities, Environmental Protection Agency, indicating that any facility utilized or to be utilized in the accomplishment of this contract is under consideration for listing on the EPA List of Violating Facilities;
- f. That it will include the provisions of paragraphs "a" through "g" in every subcontract or purchase order entered into for the purpose of accomplishing this contract, unless otherwise exempted pursuant to the EPA regulations implementing the Air or Water Act (40 CFR, Part 15.5), so that such provisions will be binding upon each subcontractor or vendor;
- g. That in the event that the contractor or the subcontractors for the construction, supply and service contracts entered into for the purpose of accomplishing



this contract were exempted from complying with the above requirements under the provisions of 40 CFR, Part 15.5(a), the exemption shall be nullified should the facility give rise to a criminal conviction (See 40 CFR, part 15.20) during the accomplishment of this contract. Furthermore, with the nullification of the exemption, the above requirements shall be effective. The contractor shall notify the government, as soon as the contractor's or the subcontractors' facility is listed for having given rise to a criminal conviction noted in 40 CFR, Part 15.20.

TRAIL MAINTENANCE AND ENHANCEMENTS AT THE BAILEYS TRAIL SYSTEM
REQUEST FOR QUOTES
ATHENS-WAYNE OUTDOOR ASSET DEVELOPMENT CORPORATION

ATTACHMENT E. MAPS

A.

Project Components

-  Bullfrog Loop Trail
- Trail Repair Locations**
 -  Broad-Based Drainage Dip (8-10' wide knick face with 3-5% outslope)
 -  Insloped Turn Redevelopment to meet A-MTB needs
 -  Rock Armor: New Armoring

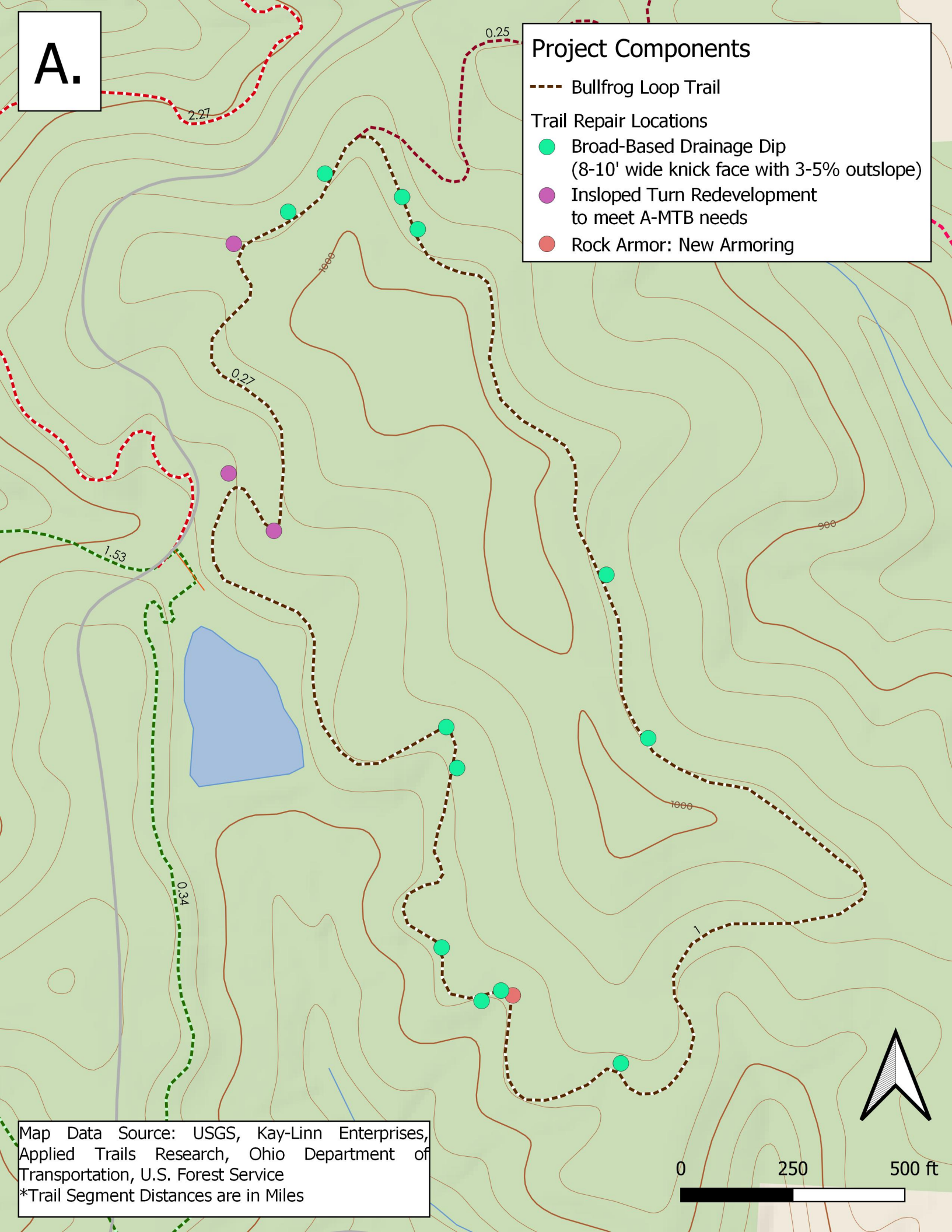

Map Data Source: USGS, Kay-Linn Enterprises, Applied Trails Research, Ohio Department of Transportation, U.S. Forest Service
*Trail Segment Distances are in Miles

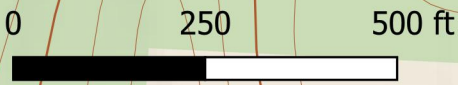

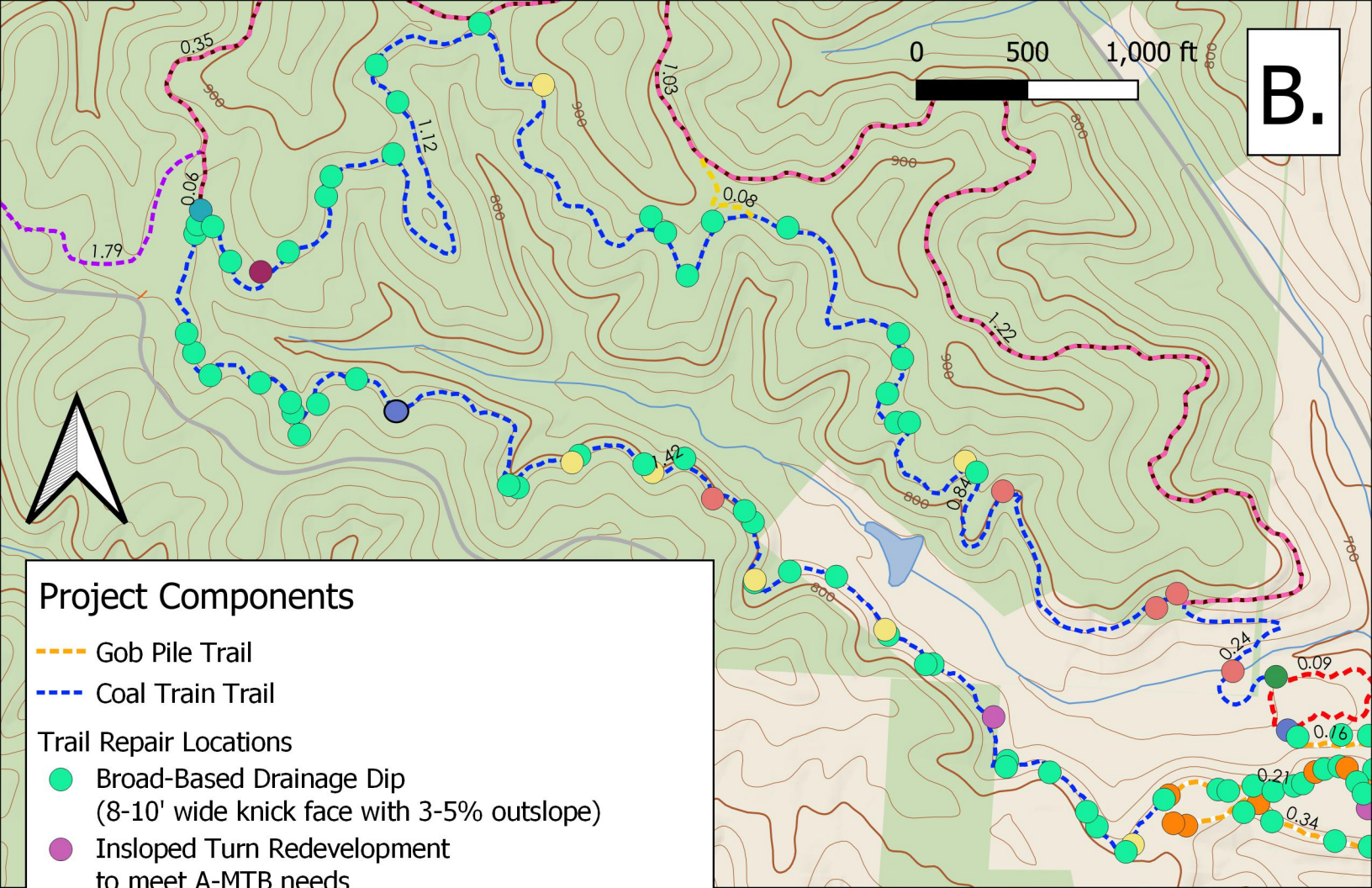

B.

Project Components

- Gob Pile Trail
- Coal Train Trail
- Trail Repair Locations**
- Broad-Based Drainage Dip (8-10' wide knick face with 3-5% outslope)
- Insloped Turn Redevelopment to meet A-MTB needs
- Rock Armor: New Armoring
- Rock Armor: Addition
- Raised Tread (borrow pitting from adjacent to the trail to bring the surface higher than the surrounding flat ground)
- Arched Culvert (96" long x 1/2 48" Diameter) Replacement
- Aggregate Surfacing, 640'
- Re-establish 70' Berm
- Reconfigure Trail Junction

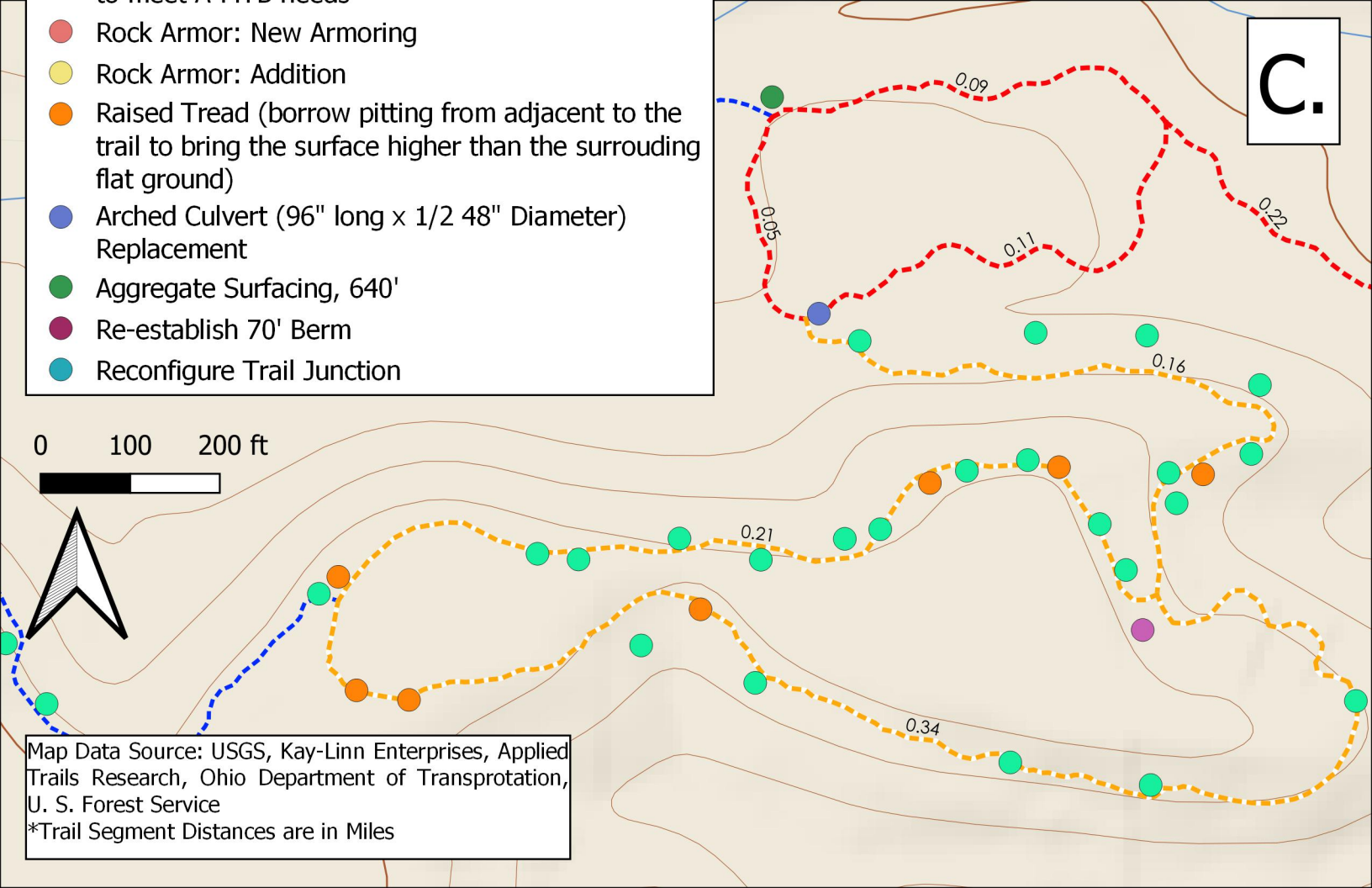

C.

Map Data Source: USGS, Kay-Linn Enterprises, Applied Trails Research, Ohio Department of Transportation, U. S. Forest Service
 *Trail Segment Distances are in Miles

TRAIL MAINTENANCE AND ENHANCEMENTS AT THE BAILEYS TRAIL SYSTEM
REQUEST FOR QUOTES
ATHENS-WAYNE OUTDOOR ASSET DEVELOPMENT CORPORATION

ATTACHMENT F. SAMPLE CONTRACT FOR CONSTRUCTION SERVICES

TRAIL MAINTENANCE AND ENHANCEMENTS AT THE BAILEYS TRAIL SYSTEM
REQUEST FOR QUOTES
ATHENS-WAYNE OUTDOOR ASSET DEVELOPMENT CORPORATION

**SAMPLE CONTRACT FOR CONSTRUCTION SERVICES TRAIL
CONSTRUCTION**

BETWEEN

**ATHENS-WAYNE OUTDOOR ASSET
DEVELOPMENT CORPORATION**

AND

(INSERT AWARDEES NAME)

This CONTRACT FOR CONSTRUCTION SERVICES is hereby made and entered into by and between the OUTDOOR RECREATION COUNCIL OF APPALACHIA (ORCA) and (INSERT AWARDEES NAME).

TRAIL MAINTENANCE AND ENHANCEMENTS AT THE BAILEYS TRAIL SYSTEM
REQUEST FOR QUOTES
ATHENS-WAYNE OUTDOOR ASSET DEVELOPMENT CORPORATION

Background:

(INSERT PROJECT BACKGROUND / DETAILS HERE)

I. PURPOSE

The purpose of this Contract for CONSTRUCTION SERVICES is to have completed approximately (PROJECT SCOPE) as defined and located by Owner's Representative and presented in the (PROJECT NAME) Construction Documents, incorporated hereinto.

II. MUTUAL AGREEMENTS AND UNDERSTANDINGS

1.) PRINCIPAL CONTACTS.

Individuals listed below are authorized to act in their respective areas for matters related to this project:

For ORCA:

Jessie Powers

Director, Outdoor Recreation Council of Appalachia

8 E. Washington St.

Athens, OH 45701

(740) 517-8445

jessie@orcaohio.com

For Wayne National Forest:

Kevin Green

District Recreation Program Manager, Wayne National Forest 13700 US Highway 33

Nelsonville, OH 45764

(541) 620-3565

Kevin.green@usda.gov

Owner's Representative:

Jeremy Wimpey, Applied Trails Research

TRAIL MAINTENANCE AND ENHANCEMENTS AT THE BAILEYS TRAIL SYSTEM
REQUEST FOR QUOTES
ATHENS-WAYNE OUTDOOR ASSET DEVELOPMENT CORPORATION

(443) 629-2630

Jeremyw@appliedtrailsresearch.com

2.) Any communications affecting the operations or activities covered by this contract given by ORCA, AWOADC, Awardee's Name, or Wayne National Forest are sufficient only if in writing and delivered in person, mailed or transmitted electronically to all Principal Contacts listed above.

3.) This contract in no way restricts ORCA & AWOADC or Awardee's Name from participating in similar activities with other public or private agencies, organizations or individuals.

4.) ELIGIBLE WORKERS. Awardee's Name shall ensure that all employees complete the I-9 form to certify that they are eligible for lawful employment under the Immigration and Nationality Act (8 USC 1324a). Awardee's Name shall comply with the regulations regarding certification and retention of the completed forms. These requirements also apply to any contract awarded under this contract.

III. SPECIFIC CONTRACTUAL OBLIGATIONS

The following provisions are hereby imposed upon this Contract. All provisions must be included in any contract/sub-contract awarded with association to the (PROJECT NAME)

1. NONDISCRIMINATION – In accordance with Federal law and U.S. Department of Agriculture policy, this institution is prohibited from discriminating on the basis of race, color, national origin, sex, age or disability.
2. NON-FEDERAL STATUS FOR COOPERATOR PARTICIPANT LIABILITY – Contractor employees, volunteers and program participants shall not be deemed to be Federal employees for any purpose including Chapter 171 of Title 28, United States Code (Federal Tort Claim Act) and Chapter 81 of Title 5, United States Code (OWCP).
3. The use of small businesses, minority-owned firms and women's business enterprises is encouraged.
4. (PREVAILING WAGE RULES APPLICABLE TO THE PROJECT DESCRIBED HERE)

IV. APPLICABLE DOCUMENTS

TRAIL MAINTENANCE AND ENHANCEMENTS AT THE BAILEYS TRAIL SYSTEM
REQUEST FOR QUOTES
ATHENS-WAYNE OUTDOOR ASSET DEVELOPMENT CORPORATION

All work hereunder shall be completed in accordance and acknowledgement of the following documents.

(SPECIFICATION DOCUMENTS LIST)

V. CONSTRUCTION OVERSIGHT

Construction activities will be overseen by ORCA & AWOADC, via the Owner's Representative, and Wayne National Forest personnel. Awardee's Name shall be required to respond to directions and suggestions as provided by the Owner's Representative which relate to construction techniques, quality of work and specific trail amenities and routes. Awardee's Name shall be required to respond to directions from Wayne National Forest personnel which relate to use and protection of properties of the United States Department of Agriculture, National Forest Service not directly involved in trail construction such as materials and equipment staging areas or issues relating to safety and intrusions upon other forest users. All invoices presented by Awardee's Name to ORCA will be reviewed to verify completeness of work presented for payment.

VI. CONTRACT PRICE

AWOADC hereby agrees to pay to (Awardee's Name) an amount not greater than \$ (Amount) for completion of the aforementioned scope of work. Any increases to this amount shall be as agreed upon by AWOADC and Awardee's Name based upon significant and appropriate expansion of the defined Scope of Work as delineated as of the date of this contract.

VII. TERMINATION

The obligation to provide further services under this Agreement may be terminated by the Owner with or without cause upon ten (10) days written notice. On termination by Owner, Owner shall pay to Contractor all amounts owing for services performed up to the date of termination. If there is a dispute as to the amount owing to Contractor, Owner shall pay those amounts which are not subject to dispute and place the remainder in a separate account pending resolution of the dispute.

VIII. ACCESS TO THE SITE(S)

Contractor will have access to the site(s) for activities necessary for the performance of its services. Contractor is responsible for providing notification of field work two weeks in advance to the Owner.

IX. INSURANCE.

Contractor shall maintain during the course of the project insurance coverage as stated in the attached Insurance Policy of _____ commercial general liability, automobile, workers compensation, and professional liability. ORCA & AWOADC reserve the right to accept minor variations in Insurance requirements so long as contractors comply with all state and federal laws.

X. DISPUTE RESOLUTION.

It is agreed by both parties that they will attempt to resolve all unsettled claims, counterclaims, disputes, or other matters in question arising out of or related to this Agreement by mediation. This provision can be waived by mutual consent of the parties, the parties recognizing that voluntary mediation requires the commitment and willingness of both parties to engage in the mediation process. In the event the parties are unable to resolve the claim by mediation, the dispute will be litigated in the Common Pleas Court for Athens County, Ohio.

XI. MISCELLANEOUS.

Modifications. Any modifications to this Agreement, including any changes for additional services, shall be in writing signed by both parties.

XII. GOVERNING LAW.

This Agreement shall be governed by the law of the State of Ohio and performed in compliance with all state and federal regulations.

XIII. NOTICES.

TRAIL MAINTENANCE AND ENHANCEMENTS AT THE BAILEYS TRAIL SYSTEM
REQUEST FOR QUOTES
ATHENS-WAYNE OUTDOOR ASSET DEVELOPMENT CORPORATION

Written notices shall be provided to the parties at the addresses provided herein.
Not assignable. No assignment or transfer of this Agreement, or any part thereof, (or of any money due or to grow due thereon), shall be made by Contractor without the express written consent of the Owner.

XIV. SEVERABILITY.

If any term or provision of this Agreement or any application thereof shall be invalid or unenforceable, such term or provision shall be deemed to be severed from this Agreement, and the remainder of this Agreement and any other application of such term or provision shall not be affected or invalidated thereby.

XV. AGREEMENTS AND ADDITIONAL CERTIFICATIONS (ATTACHMENTS)

- A. BID GUARANTY AND CONTRACT BOND
- B. NON-COLLUSION AFFIDAVIT
- C. CERTIFICATION REGARDING DEBARMENT, SUSPENSION, AND OTHER RESPONSIBILITY MATTERS PRIMARY COVERED TRANSACTIONS
- D. AFFIDAVIT IN COMPLIANCE WITH SECTION 3517.13 OF THE OHIO REVISED CODE
- E. ADDITIONAL CERTIFICATIONS
- F. BONDING AND INSURANCE REQUIREMENTS
- G. EXPERIENCE STATEMENT OF BIDDER
- H. SALES AND USE TAX CONTRACTOR'S EXEMPTION CERTIFICATE
- I. DMA PUBLIC EMPLOYMENT
- J. FORM W-9

This Contract is hereby entered into and agreed upon by:

Awardee's Name

TRAIL MAINTENANCE AND ENHANCEMENTS AT THE BAILEYS TRAIL SYSTEM
REQUEST FOR QUOTES
ATHENS-WAYNE OUTDOOR ASSET DEVELOPMENT CORPORATION

Date

Jessie Powers, ORCA/AWOADC Executive Director

Date

TRAIL MAINTENANCE AND ENHANCEMENTS AT THE BAILEYS TRAIL SYSTEM
REQUEST FOR QUOTES
ATHENS-WAYNE OUTDOOR ASSET DEVELOPMENT CORPORATION

ATTACHMENT: CHANGE ORDER FORM SAMPLE

Original CONTRACT PRICE: _____

Original SCOPE OF WORK & proposed CHANGE:

The CONTRACT PRICE due to this CHANGE ORDER will be _____ by: _____

CONTRACT PRICE FOLLOWING Change Order 1: _____

Change to CONTRACT TIME: _____

The date for completion of all WORK will be: _____

Requested by: _____

Recommended by: _____

Accepted by: _____

(Change Orders will be approved/ agreed to by: Contractor, Construction Manager, Land
Manager, and Project Manager.)

TRAIL MAINTENANCE AND ENHANCEMENTS AT THE BAILEYS TRAIL SYSTEM
REQUEST FOR QUOTES
ATHENS-WAYNE OUTDOOR ASSET DEVELOPMENT CORPORATION

ATTACHMENT G. DAVIS-BACON WAGE DETERMINATIONS

Superseded General Decision Number: OH20230001

State: Ohio

Construction Types: Heavy and Highway

Counties: Ohio Statewide.

Heavy and Highway Construction Projects

Note: Contracts subject to the Davis-Bacon Act are generally required to pay at least the applicable minimum wage rate required under Executive Order 14026 or Executive Order 13658. Please note that these Executive Orders apply to covered contracts entered into by the federal government that are subject to the Davis-Bacon Act itself, but do not apply to contracts subject only to the Davis-Bacon Related Acts, including those set forth at 29 CFR 5.1(a)(1).

<p>If the contract is entered into on or after January 30, 2022, or the contract is renewed or extended (e.g., an option is exercised) on or after January 30, 2022:</p>	<ul style="list-style-type: none"> . Executive Order 14026 generally applies to the contract. . The contractor must pay all covered workers at least \$17.20 per hour (or the applicable wage rate listed on this wage determination, if it is higher) for all hours spent performing on the contract in 2024.
<p>If the contract was awarded on or between January 1, 2015 and January 29, 2022, and the contract is not renewed or extended on or after January 30, 2022:</p>	<ul style="list-style-type: none"> . Executive Order 13658 generally applies to the contract. . The contractor must pay all covered workers at least \$12.90 per hour (or the applicable wage rate listed on this wage determination, if it is higher) for all hours spent performing on that contract in 2024.

The applicable Executive Order minimum wage rate will be adjusted annually. If this contract is covered by one of the Executive Orders and a classification considered necessary for performance of work on the contract does not appear on this wage determination, the contractor must still submit a conformance request.

Additional information on contractor requirements and worker protections under the Executive Orders is available at <http://www.dol.gov/whd/govcontracts>.

Modification Number	Publication Date
0	01/05/2024
1	01/26/2024
2	03/08/2024
3	04/05/2024

* BROH0001-001 06/01/2023

DEFIANCE, FULTON (Excluding Fulton, Amboy & Swan Creek

Townships), HENRY (Excluding Monroe, Bartlow, Liberty, Washington, Richfield, Marion, Damascus & Townships & that part of Harrison Township outside corporate limits of city of Napoleon), PAULDING, PUTNAM and WILLIAMS COUNTIES

	Rates	Fringes
Bricklayer, Stonemason.....	\$ 32.40	19.30

 * BROH0001-004 06/01/2023

	Rates	Fringes
CEMENT MASON/CONCRETE FINISHER...	\$ 32.40	19.30

 * BROH0003-002 06/01/2023

FULTON (Townships of Amboy, Swan Creek & Fulton), HENRY (Townships of Washington, Damascus, Richfield, Bartlow, Liberty, Harrison, Monroe, & Marion), LUCAS and WOOD (Townships of Perrysburg, Ross, Lake, Troy, Freedom, Montgomery, Webster, Center, Portage, Middleton, Plain, Liberty, Henry, Washington, Weston, Milton, Jackson & Grand Rapids) COUNTIES

	Rates	Fringes
Bricklayer, Stonemason.....	\$ 32.40	19.30

 BROH0005-003 06/01/2020

CUYAHOGA, LORAIN & MEDINA (Hinckley, Granger, Brunswick, Liverpool, Montville, York, Homer, Harrisville, Chatham, Litchfield & Spencer Townships and the city of Medina)

	Rates	Fringes
BRICKLAYER		
BRICKLAYERS; CAULKERS;		
CLEANERS; POINTERS; &		
STONEMASONS.....	\$ 36.64	17.13
SANDBLASTERS.....	\$ 36.39	17.13
SEWER BRICKLAYERS & STACK		
BUILDERS.....	\$ 36.64	17.13
SWING SCAFFOLDS.....	\$ 37.14	17.13

 * BROH0006-005 06/01/2023

CARROLL, COLUMBIANA (Knox, Butler, West & Hanover Townships), STARK & TUSCARAWAS

	Rates	Fringes
Bricklayer, Stonemason.....	\$ 32.40	19.30

 * BROH0007-002 06/01/2023

LAWRENCE

	Rates	Fringes
Bricklayer, Stonemason.....	\$ 32.40	19.30

 * BROH0007-005 06/01/2023

PORTAGE & SUMMIT

Rates Fringes

BRICKLAYER.....\$ 32.40 19.30

* BROH0007-010 06/01/2023

PORTAGE & SUMMIT

Rates Fringes

MASON - STONE.....\$ 32.40 19.30

* BROH0008-001 06/01/2023

COLUMBIANA (Salem, Perry, Fairfield, Center, Elk Run, Middleton, & Unity Townships and the city of New Waterford), MAHONING & TRUMBULL

Rates Fringes

BRICKLAYER.....\$ 32.40 19.30

* BROH0009-002 06/01/2023

BELMONT & MONROE COUNTIES and the Townships of Warren & Mt. Pleasant and the Village of Dillonvale in JEFFERSON COUNTY

Rates Fringes

Bricklayer, Stonemason.....\$ 32.40 19.30
Refractory.....\$ 31.45 19.01

* BROH0010-002 06/01/2023

COLUMBIANA (St. Clair, Madison, Wayne, Franklin, Washington, Yellow Creek & Liverpool Townships) & JEFFERSON (Brush Creek & Saline Townships)

Rates Fringes

Bricklayer, Stonemason.....\$ 32.40 19.30

* BROH0014-002 06/01/2023

HARRISON & JEFFERSON (Except Mt. Pleasant, Warren, Brush Creek, Saline & Salineville Townships & the Village of Dillonvale)

Rates Fringes

Bricklayer, Stonemason.....\$ 32.40 19.30

* BROH0016-002 06/01/2023

ASHTABULA, GEAUGA, and LAKE COUNTIES

Rates Fringes

Bricklayer, Stonemason.....\$ 32.40 19.30

* BROH0018-002 06/01/2023

BROWN, BUTLER, CLERMONT, HAMILTON, PREBLE (Gasper, Dixon, Israel, Lanier, Somers & Gratis Townships) & WARREN COUNTIES:

Rates Fringes

Bricklayer, Stonemason.....\$ 32.40 19.30

* BROH0022-004 06/01/2023

CHAMPAIGN, CLARK, CLINTON, DARKE, GREENE, HIGHLAND, LOGAN,
MIAMI, MONTGOMERY, PREBLE (Jackson, Monroe, Harrison, Twin,
Jefferson & Washington Townships) and SHELBY COUNTIES

Rates Fringes
Bricklayer, Stonemason.....\$ 32.40 19.30

* BROH0032-001 06/01/2023

GALLIA & MEIGS

Rates Fringes
Bricklayer, Stonemason.....\$ 32.40 19.30

* BROH0035-002 06/01/2023

ALLEN, AUGLAIZE, MERCER and VAN WERT COUNTIES

Rates Fringes
Bricklayer, Stonemason.....\$ 32.40 19.30

* BROH0039-002 06/01/2023

ADAMS & SCIOTO

Rates Fringes
Bricklayer, Stonemason.....\$ 32.40 19.30

* BROH0040-003 06/01/2023

ASHLAND, CRAWFORD, HARDIN, HOLMES, MARION, MORROW, RICHLAND,
WAYNE and WYANDOT (Except Crawford, Ridge, Richland & Tymochtee
Townships) COUNTIES

Rates Fringes
Bricklayer, Stonemason.....\$ 32.40 19.30

FOOTNOTE: Layout Man and Sawman rate: \$1.00 per hour above
journeyman rate.
Free standing stack work ground level to top of stack;
Sandblasting and laying of carbon masonry material in swing
stage and/or scaffold; Ramming and spading of plastics and
gunniting: \$1.50 per hour above journeyman rate.
""Hot"" work: \$2.50 above journeyman rate.

* BROH0044-002 06/01/2023

Rates Fringes
Bricklayer, Stonemason

COSHOCTON, FAIRFIELD,
GUERNSEY, HOCKING, KNOX,
KICKING, MORGAN,
MUSKINGUM, NOBLE (Beaver,
Buffalo, Seneca & Wayne
Townships) & PERRY
COUNTIES:.....\$ 32.40 19.30

BROH0045-002 06/01/2021

FAYETTE, JACKSON, PIKE, ROSS and VINTON COUNTIES

	Rates	Fringes
Bricklayer, Stonemason.....	\$ 30.40	17.66

* BROH0046-002 06/01/2023

ERIE, HANCOCK, HURON, OTTAWA, SANDUSKY, SENECA, WOOD (Perry & Bloom Townships) and WYANDOT (Tymochtee, Crawford, Ridge & Richland Townships) COUNTIES & the Islands of Lake Erie north of Sandusky

	Rates	Fringes
Bricklayer, Stonemason.....	\$ 32.40	19.30

FOOTNOTE: Layout Man and Sawman rate: \$1.00 per hour above journeyman rate.
Free standing stack work ground level to top of stack;
Sandblasting and laying of carbon masonry material in swing stage and/or scaffold; Ramming and spading of plastics and gunniting: \$1.50 per hour above journeyman rate.
""Hot"" work: \$2.50 above journeyman rate.

* BROH0052-001 06/01/2023

ATHENS COUNTY

	Rates	Fringes
Bricklayer, Stonemason.....	\$ 32.40	19.30

* BROH0052-003 06/01/2023

NOBLE (Brookfield, Noble, Center, Sharon, Olive, Enoch, Stock, Jackson, Jefferson & Elk Townships) and WASHINGTON COUNTIES

	Rates	Fringes
Bricklayer, Stonemason.....	\$ 32.40	19.30

* BROH0055-003 06/01/2023

DELAWARE, FRANKLIN, MADISON, PICKAWAY and UNION COUNTIES

	Rates	Fringes
Bricklayer, Stonemason.....	\$ 32.40	19.30

CARP0003-004 05/01/2017

MAHONING & TRUMBULL

	Rates	Fringes
CARPENTER.....	\$ 26.20	17.42

CARP0069-003 05/01/2017

CARROLL, STARK, TUSCARAWAS & WAYNE

	Rates	Fringes
--	-------	---------

CARPENTER.....	\$ 25.98	15.98

CARP0069-006 05/01/2017		
COSHOCTON, HOLMES, KNOX & MORROW		
	Rates	Fringes
CARPENTER.....	\$ 24.04	15.29

CARP0171-002 05/01/2019		
BELMONT, COLUMBIANA, HARRISON, JEFFERSON & MONROE		
	Rates	Fringes
CARPENTER.....	\$ 27.37	20.02

CARP0200-002 05/01/2023		
ADAMS, ATHENS, DELAWARE, FAIRFIELD, FAYETTE, FRANKLIN, GALLIA, GUERNSEY, HIGHLAND, HOCKING, JACKSON, LAWRENCE, LICKING, MADISON, MARION, MEIGS, MORGAN, MUSKINGUM, NOBLE, PERRY, PICKAWAY, PIKE, ROSS, SCIOTO, UNION, VINTON and WASHINGTON COUNTIES		
	Rates	Fringes
CARPENTER.....	\$ 32.42	21.42
Diver.....	\$ 39.41	10.40
PILEDRIVERMAN.....	\$ 32.42	21.42

CARP0248-005 07/01/2008		
LUCAS & WOOD		
	Rates	Fringes
CARPENTER.....	\$ 27.27	14.58

CARP0248-008 07/01/2008		
	Rates	Fringes
CARPENTER DEFIANCE, FULTON, HANCOCK, HENRY, PAULDING & WILLIAMS COUNTIES.....	\$ 23.71	13.28

CARP0254-002 05/01/2017		
ASHTABULA, CUYAHOGA, GEAUGA & LAKE		
	Rates	Fringes
CARPENTER.....	\$ 32.40	16.97

CARP0372-002 05/01/2023		
ALLEN, AUGLAIZE, HARDIN, MERCER, PUTNAM & VAN WERT		
	Rates	Fringes
CARPENTER.....	\$ 28.85	24.59

CARP0639-003 05/01/2017		
MEDINA, PORTAGE & SUMMIT		

	Rates	Fringes
CARPENTER.....	\$ 30.42	16.99

 CARP0735-002 05/01/2023

ASHLAND, ERIE, HURON, LORAIN & RICHLAND

	Rates	Fringes
CARPENTER.....	\$ 31.62	21.63

 CARP1311-001 05/01/2017

BROWN, BUTLER, CHAMPAIGN, CLARK, CLERMONT, CLINTON, DARKE,
 GREENE, HAMILTON, LOGAN, MIAMI, MONTGOMERY, PREBLE, SHELBY &
 WARREN

	Rates	Fringes
Carpenter & Piledrivermen.....	\$ 29.34	15.95
Diver.....	\$ 40.58	9.69

 CARP1393-002 07/01/2008

CRAWFORD, DEFIANCE, FULTON, HANCOCK, HENRY, LUCAS, OTTAWA,
 PAULDING, SANDUSKY, SENECA, WILLIAMS & WOOD

	Rates	Fringes
Piledrivermen & Diver's Tender...	\$ 27.30	16.05

DIVERS - \$250.00 per day

 CARP1393-003 07/01/2008

ALLEN, AUGLAIZE, HARDIN, MERCER, PUTNAM, VAN WERT & WYANDOT

	Rates	Fringes
Piledrivermen & Diver's Tender...	\$ 25.15	15.92

DIVERS - \$250.00 per day

 CARP1871-006 05/01/2017

BELMONT, HARRISON, & MONROE

	Rates	Fringes
Diver, Wet.....	\$ 48.11	17.33
Piledrivermen; Diver, Dry.....	\$ 32.07	17.33

 CARP1871-008 05/01/2017

ASHLAND, ASHTABULA, CUYAHOGA, ERIE, GEAUGA, HURON, LAKE,
 LORAIN, MEDINA, PORTAGE, RICHLAND & SUMMIT

	Rates	Fringes
Diver, Wet.....	\$ 45.80	18.84
Piledrivermen; Diver, Dry.....	\$ 30.53	18.84

 CARP1871-014 05/01/2017

CARROLL, STARK, TUSCARAWAS & WAYNE

Rates Fringes

Diver, Wet.....	\$ 38.34	16.95
Piledrivermen; Diver, Dry.....	\$ 25.56	16.95

CARP1871-015 05/01/2017

COSHOCTON, HOLMES, KNOX & MORROW

Rates Fringes

Diver, Wet.....	\$ 37.34	16.07
Piledrivermen; Diver, Dry.....	\$ 24.89	16.07

CARP1871-017 05/01/2017

MAHONING & TRUMBULL

Rates Fringes

Diver, Wet.....	\$ 40.65	17.62
Piledrivermen; Diver, Dry.....	\$ 27.10	17.62

CARP2235-012 01/01/2014

COLUMBIANA & JEFFERSON

Rates Fringes

PILEDRIVERMAN.....	\$ 31.74	16.41
--------------------	----------	-------

CARP2239-001 07/01/2008

CRAWFORD, OTTAWA, SANDUSKY, SENECA & WYANDOT

Rates Fringes

CARPENTER.....	\$ 23.71	13.28
----------------	----------	-------

ELEC0008-002 05/29/2023

DEFIANCE, FULTON, HANCOCK, HENRY, LUCAS, OTTAWA, PAULDING,
PUTNAM, SANDUSKY, SENECA, WILLIAMS & WOOD

Rates Fringes

CABLE SPLICER.....	\$ 38.98	18.96
ELECTRICIAN.....	\$ 46.38	4.5%+21.96

ELEC0032-003 12/04/2023

ALLEN, AUGLAIZE, HARDIN, LOGAN, MERCER, SHELBY, VAN WERT &
WYANDOT (Crawford, Jackson, Marseilles, Mifflin, Ridgeland,
Ridge & Salem Townships)

Rates Fringes

ELECTRICIAN.....	\$ 35.17	22.82
------------------	----------	-------

ELEC0038-002 04/24/2023

CUYAHOGA, GEAUGA (Bainbridge, Chester & Russell Townships) &
LORAIN (Columbia Township)

Rates Fringes

ELECTRICIAN

Excluding Sound &
 Communications Work.....\$ 43.13 23.31

FOOTNOTES;
 a. 6 Paid Holidays: New Year's Day; Memorial Day; July 4th;
 Labor Day; Thanksgiving Day; & Christmas Day
 b. 1 week's paid vacation for 1 year's service; 2 weeks' paid
 vacation for 2 or more years' service

 ELEC0038-008 04/24/2023

CUYAHOGA, GEAUGA (Bainbridge, Chester & Russell Townships) &
 LORAIN (Columbia Township)

	Rates	Fringes
Sound & Communication Technician		
Communications Technician...\$ 29.80	29.80	13.80
Installer Technician.....\$ 28.55	28.55	13.76

FOOTNOTES;
 a. 6 Paid Holidays: New Year's Day; Memorial Day; July 4th;
 Labor Day; Thanksgiving Day; & Christmas Day
 b. 1 week's paid vacation for 1 year's service; 2 weeks' paid
 vacation for 2 or more years' service

 ELEC0064-003 11/27/2023

COLUMBIANA (Butler, Fairfield, Perry, Salem & Unity Townships)
 MAHONING (Austintown, Beaver, Berlin, Boardman, Canfield,
 Ellsworth, Coitsville, Goshen, Green, Jackson, Poland,
 Springfield & Youngstown Townships), & TRUMBULL (Hubbard &
 Liberty Townships)

	Rates	Fringes
ELECTRICIAN.....\$ 37.90	37.90	20.08

 ELEC0071-001 01/01/2019

ASHLAND, CHAMPAIGN, CLARK, COSHOCTON, CRAWFORD, DELAWARE,
 FAIRFIELD, FAYETTE, FRANKLIN, GUERNSEY, HIGHLAND, HOCKING,
 JACKSON (Coal, Jackson, Liberty, Milton, Washington & Wellston
 Townships), KNOX, LICKING, MADISON, MARION, MONROE, MORGAN,
 MORROW, MUSKINGUM, NOBLE, PERRY, PICKAWAY, PIKE (Beaver,
 Benton, Jackson, Mifflin, Pebble, Peepee, Perry & Seal
 Townships), RICHLAND, ROSS, TUSCARAWAS (Auburn, Bucks, Clay,
 Jefferson, Oxford, Perry, Salem, Rush, Washington & York
 Townships), UNION, VINTON (Clinton, Eagle, Elk, Harrison,
 Jackson, Richland & Swan Townships), and WASHINGTON COUNTIES

	Rates	Fringes
Line Construction		
Equipment Operators.....\$ 33.62	33.62	13.40
Groundmen.....\$ 24.17	24.17	11.32
Linemen & Cable Splicers....\$ 38.27	38.27	14.42

 ELEC0071-004 01/01/2019

AUGLAIZE, CLINTON, DARKE, GREENE, LOGAN, MERCER, MIAMI,
 MONTGOMERY, PREBLE, and SHELBY COUNTIES

Rates Fringes

Line Construction		
Equipment Operator.....	\$ 33.62	13.40
Groundman.....	\$ 24.17	11.32
Lineman & Cable Splicers....	\$ 38.27	14.42

ELEC0071-005 12/31/2018

ASHTABULA, CUYAHOGA, GEAUGA, LAKE & LORAIN

Rates Fringes

LINE CONSTRUCTION: Equipment Operator		
DOT/Traffic Signal & Highway Lighting Projects...	\$ 32.44	14.10
Municipal Power/Transit Projects.....	\$ 40.10	16.42
LINE CONSTRUCTION: Groundman		
DOT/Traffic Signal & Highway Lighting Projects...	\$ 25.06	12.26
Municipal Power/Transit Projects.....	\$ 31.19	14.11
LINE CONSTRUCTION: Linemen/Cable Splicer		
DOT/Traffic Signal & Highway Lighting Projects...	\$ 36.13	15.03
Municipal Power/Transit Projects.....	\$ 44.56	17.58

ELEC0071-008 01/01/2019

COLUMBIANA, MAHONING, and TRUMBULL COUNTIES

Rates Fringes

Line Construction		
Equipment Operator.....	\$ 33.62	13.40
Groundman.....	\$ 24.17	11.32
Lineman & Cable Splicers....	\$ 38.27	14.42

ELEC0071-010 01/01/2019

BELMONT, CARROLL, HARRISON, HOLMES, JEFFERSON, MEDINA, PORTAGE, STARK, SUMMIT, and WAYNE COUNTIES

Rates Fringes

Line Construction		
Equipment Operator.....	\$ 33.62	13.40
Groundman.....	\$ 24.17	11.32
Lineman & Cable Splicers....	\$ 38.27	14.42

ELEC0071-013 01/01/2019

BROWN, BUTLER, CLERMONT, HAMILTON, and WARREN COUNTIES

Rates Fringes

Line Construction		
Equipment Operator.....	\$ 33.62	13.40
Groundman.....	\$ 24.17	11.32
Lineman & Cable Splicers....	\$ 38.27	14.42

ELEC0071-014 01/01/2019

ADAMS, ATHENS, GALLIA, JACKSON (Bloomfield, Franklin, Hamilton, Lick, Jefferson, Scioto & Madison Townships), LAWRENCE, MEIGS,

PIKE (Camp Creek, Marion, Newton, Scioto, Sunfish & Union Townships), SCIOTO & VINTON (Brown, Knox, Madison, Vinton & Wilkesville Townships)

	Rates	Fringes
Line Construction		
Equipment Operator.....	\$ 33.62	13.40
Groundman.....	\$ 24.17	11.32
Lineman & Cable Splicers....	\$ 38.27	14.42

 ELEC0082-002 12/04/2023

CLINTON, DARKE, GREENE, MIAMI, MONTGOMERY, PREBLE & WARREN
 (Wayne, Clear Creek & Franklin Townships)

	Rates	Fringes
ELECTRICIAN.....	\$ 36.00	21.99

 * ELEC0082-006 11/28/2022

CLINTON, DARKE, GREENE, MIAMI, MONTGOMERY, PREBLE & WARREN
 (Wayne, Clear Creek & Franklin Townships)

	Rates	Fringes
Sound & Communication Technician		
Cable Puller.....	\$ 13.10 **	4.76
Installer/Technician.....	\$ 26.20	13.89

 * ELEC0129-003 02/26/2024

LORAIN (Except Columbia Township) & MEDINA (Litchfield & Liverpool Townships)

	Rates	Fringes
ELECTRICIAN.....	\$ 41.40	18.36

 * ELEC0129-004 02/26/2024

ERIE & HURON (Lyme, Ridgefield, Norwalk, Townsend, Wakeman, Sherman, Peru, Bronson, Hartland, Clarksfield, Norwich, Greenfield, Fairfield, Fitchville & New London Townships)

	Rates	Fringes
ELECTRICIAN.....	\$ 41.40	18.36

 ELEC0141-003 06/01/2023

BELMONT COUNTY

	Rates	Fringes
CABLE SPLICER.....	\$ 30.63	25.87
ELECTRICIAN.....	\$ 35.70	28.87

 ELEC0212-003 11/26/2018

BROWN, CLERMONT & HAMILTON

	Rates	Fringes
--	-------	---------

Sound & Communication
 Technician.....\$ 24.35 10.99

 ELEC0212-005 06/05/2023

BROWN, CLERMONT, and HAMILTON COUNTIES

	Rates	Fringes
ELECTRICIAN.....	\$ 34.41	21.55

 ELEC0245-001 08/29/2022

ALLEN, HARDIN, VAN WERT & WYANDOT (Crawford, Jackson, Marseilles, Mifflin, Richland, Ridge & Salem Townships)

	Rates	Fringes
Line Construction		
Equipment Operator.....	\$ 32.37	26.5%+7.25
Groundman Truck Driver.....	\$ 19.35	7.00+27.25%
Lineman.....	\$ 44.22	7.00+27.25%

FOOTNOTE: a. Half day's Paid Holiday: The last 4 hours of the workday prior to Christmas or New Year's Day

 ELEC0245-003 01/01/2024

DEFIANCE, FULTON, HANCOCK, HENRY, HURON, LUCAS, OTTAWA, PAULDING, PUTNAM, SANDUSKY, SENECA, WILLIAMS, and WOOD COUNTIES

	Rates	Fringes
Line Construction		
Cable Splicer.....	\$ 52.53	7.75+27%
Groundman/Truck Driver.....	\$ 19.99	7.75+27%
Heli-arc Welding.....	\$ 45.98	7.75+27%
Lineman.....	\$ 45.68	7.75+27%
Operator - Class 1.....	\$ 36.54	7.75+27%
Operator - Class 2.....	\$ 31.98	7.75+27%
Traffic Signal & Lighting Technician.....	\$ 41.11	7.75+27%

FOOTNOTE: a. 6 Observed Holidays: New Year's Day; Memorial Day; Independence Day; Labor Day; Thanksgiving Day; & Christmas Day. Employees who work on a holiday shall be paid at a rate of double their applicable classified straight-time rates for the work performed on such holiday.

 ELEC0245-004 08/28/2023

ERIE COUNTY

	Rates	Fringes
Line Construction		
Cable Splicer.....	\$ 49.14	26.75%+6.75
Cablesplicer.....	\$ 52.76	27%+7.50
Groundman/Truck Driver.....	\$ 20.07	27%+7.50
Lineman.....	\$ 45.88	27%+7.50
Operator - Class 1.....	\$ 36.70	27%+7.50
Operator - Class 2.....	\$ 32.12	27%+7.50

FOOTNOTE: a. 6 Observed Holidays: New Year's Day; Memorial Day; Independence Day; Labor Day; Thanksgiving Day; &

Christmas Day. Employees who work on a holiday shall be paid at a rate of double their applicable classified straight-time rates for the work performed on such holiday.

ELEC0246-001 10/30/2023

	Rates	Fringes
ELECTRICIAN.....	\$ 42.50	55%+13.88

FOOTNOTE: a. 1 1/2 Paid Holidays: The last scheduled workday prior to Christmas & 4 hours on Good Friday.

ELEC0306-005 05/29/2023

MEDINA (Brunswick, Chatham, Granger, Guilford, Harrisville, Hinckley, Homer, Lafayette, Medina, Montville, Sharon, Spencer, Wadsworth, Westfield & York Townships), PORTAGE (Atwater, Aurora, Brimfield, Deerfield, Franklin, Mantua, Randolph, Ravenna, Rootstown, Shalersville, Streetsboro & Suffield Townships), SUMMIT & WAYNE (Baughman, Canaan, Chester, Chippewa, Congress, Green, Milton, & Wayne Townships)

	Rates	Fringes
CABLE SPLICER.....	\$ 36.87	16.56
ELECTRICIAN.....	\$ 40.15	5.25%+20.85

ELEC0317-002 05/29/2023

GALLIA & LAWRENCE

	Rates	Fringes
CABLE SPLICER.....	\$ 32.68	18.13
ELECTRICIAN.....	\$ 37.15	28.48

ELEC0540-005 01/01/2024

CARROLL (Northern half, including Fox, Harrison, Rose & Washington Townships), COLUMBIANA (Knox Township), HOLMES, MAHONING (Smith Township), STARK, TUSCARAWAS (North of Auburn, Clay, Rush & York Townships), and WAYNE (South of Baughman, Chester, Green & Wayne Townships) COUNTIES

	Rates	Fringes
ELECTRICIAN.....	\$ 36.96	28.18

ELEC0573-003 11/27/2023

ASHTABULA (Colebrook, Wayne, Williamsfield, Orwell & Windsor Townships), GEAUGA (Auburn, Middlefield, Parkman & Troy Townships), MAHONING (Milton Township), PORTAGE (Charlestown, Edinburg, Freedom, Hiram, Nelson, Palmyra, Paris & Windham Townships), and TRUMBULL (Except Liberty & Hubbard Townships)

	Rates	Fringes
ELECTRICIAN.....	\$ 40.40	22.08

ELEC0575-001 05/29/2023

ADAMS, FAYETTE, HIGHLAND, HOCKING, JACKSON (Bloomfield, Franklin, Hamilton, Jefferson, Lick, Madison, Scioto, Coal,

Jackson, Liberty, Milton & Washington Townships), PICKAWAY (Deer Creek, Perry, Pickaway, Salt Creek & Wayne Townships), PIKE (Beaver, Benton, Jackson, Mifflin, Pebble, PeePee, Perry, Seal, Camp Creek, Newton, Scioto, Sunfish, Union & Marion Townships), ROSS, SCIOTO & VINTON (Clinton, Eagle, Elk, Harrison, Jackson, Richland & Swan Townships)

	Rates	Fringes
ELECTRICIAN.....	\$ 37.00	22.26

ELEC0648-001 08/29/2023		

BUTLER and WARREN COUNTIES (Deerfield, Hamilton, Harlan, Massie, Salem, Turtle Creek, Union & Washington Townships)

	Rates	Fringes
CABLE SPLICER.....	\$ 30.50	18.23
ELECTRICIAN.....	\$ 34.00	21.98

ELEC0673-004 01/01/2024		

ASHTABULA (Excluding Orwell, Colebrook, Williamsfield, Wayne & Windsor Townships), GEAUGA (Burton, Chardon, Claridon, Hambden, Huntsburg, Montville, Munson, Newbury & Thompson Townships) and LAKE COUNTIES

	Rates	Fringes
CABLE SPLICER.....	\$ 33.81	21.47
ELECTRICIAN.....	\$ 37.38	23.75

ELEC0683-002 05/29/2023		

CHAMPAIGN, CLARK, DELAWARE, FAIRFIELD, FRANKLIN, MADISON, PICKAWAY (Circleville, Darby, Harrison, Jackson, Madison, Monroe, Muhlenberg, Scioto, Walnut & Washington Townships), and UNION COUNTIES

	Rates	Fringes
CABLE SPLICER.....	\$ 38.75	24.19
ELECTRICIAN.....	\$ 37.75	24.16

ELEC0688-003 05/30/2022		

ASHLAND, CRAWFORD, HURON (Richmond, New Haven, Ripley & Greenwich Townships), KNOX (Liberty, Clinton, Union, Howard, Monroe, Middleberry, Morris, Wayne, Berlin, Pike, Brown & Jefferson Townships), MARION, MORROW, RICHLAND and WYANDOT (Sycamore, Crane, Eden, Pitt, Antrim & Tymochtee Townships) COUNTIES

	Rates	Fringes
ELECTRICIAN.....	\$ 32.30	21.83

ELEC0972-002 06/01/2023		

ATHENS, MEIGS, MONROE, MORGAN, NOBLE, VINTON (Brown, Knox, Madison, Vinton & Wilkesville Townships), and WASHINGTON COUNITIES

Rates Fringes

CABLE SPLICER.....	\$ 35.70	30.26
ELECTRICIAN.....	\$ 35.45	30.25

ELEC1105-001 05/29/2023

COSHOCTON, GUERNSEY, KNOX (Jackson, Clay, Morgan, Miller, Milford, Hilliar, Butler, Harrison, Pleasant & College Townships), LICKING, MUSKINGUM, PERRY, and TUSCARAWAS (Auburn, York, Clay, Jefferson, Rush, Oxford, Washington, Salem, Perry & Bucks Townships) COUNTIES

Rates Fringes

ELECTRICIAN.....	\$ 36.45	24.22
------------------	----------	-------

ENGI0018-003 05/01/2019

ASHTABULA, CUYAHOGA, ERIE, GEAUGA, LAKE, LORAIN, MEDINA, PORTAGE, and SUMMIT COUNTIES

Rates Fringes

POWER EQUIPMENT OPERATOR		
GROUP 1.....	\$ 38.63	15.20
GROUP 2.....	\$ 38.53	15.20
GROUP 3.....	\$ 37.49	15.20
GROUP 4.....	\$ 36.27	15.20
GROUP 5.....	\$ 30.98	15.20
GROUP 6.....	\$ 38.88	15.20
GROUP 7.....	\$ 39.13	15.20

OPERATING ENGINEER CLASSIFICATIONS

GROUP 1 - Air Compressor on Steel Erection; Barrier Moving Machine; Boiler Operator on Compressor or Generator when mounted on a Rig; Cableway; Combination Concrete Mixer & Tower; Concrete Plant (over 4 yd. Capacity); Concrete Pump; Crane (All Types, Including Boom Truck, Cherry Picker); Crane-Compact, Track or Rubber over 4,000 lbs. capacity; Cranes-Self Erecting, Stationary, Track or Truck (All Configurations); Derrick; Dragline; Dredge (Dipper, Clam or Suction); Elevating Grader or Euclid Loader; Floating Equipment (All Types); Gradall; Helicopter Crew (Operator-Hoist or Winch); Hoe (all types); Hoisting Engine on Shaft or Tunnel Work; Hydraulic Gantry (Lifting System); Industrial-Type Tractor; Jet Engine Dryer (D8 or D9) Diesel Tractor; Locomotive (Standard Gauge); Maintenance Operator Class A; Mixer, Paving (Single or Double Drum); Mucking Machine; Multiple Scraper; Piledriving Machine (All Types); Power Shovel; Prentice Loader; Quad 9 (Double Pusher); Rail Tamper (with auto lifting & aligning device); Refrigerating Machine (Freezer Operation); Rotary Drill, on Caisson work; Rough Terrain Fork Lift with Winch/Hoist; Side-Boom; Slip-Form Paver; Tower Derrick; Tree Shredder; Trench Machine (Over 24" wide); Truck Mounted Concrete Pump; Tug Boat; Tunnel Machine and/or Mining Machine; Wheel Excavator; and Asphalt Plant Engineer (Cleveland District Only).

GROUP 2 - Asphalt Paver; Automatic Subgrader Machine, Self-Propelled (CMI Type); Bobcat Type and/or Skid Steer Loader with Hoe Attachment Greater than 7,000 lbs.; Boring Machine More than 48"; Bulldozer; Endloader; Horizontal Directional Drill (Over 50,000 ft lbs thrust); Hydro Milling Machine; Kolman-type Loader (production type-Dirt); Lead Greaseman; Lighting & Traffic Signal Installation

Equipment (includes all groups or classifications); Material Transfer Equipment (Shuttle Buggy) Asphalt; Pettibone-Rail Equipment; Power Grader; Power Scraper; Push Cat; Rotomill (all), Grinders & Planers of All types; Trench Machine (24" wide & under); Vermeer type Concrete Saw; and Maintenance Operators (Portage and Summit Counties Only).

GROUP 3 - A-Frame; Air Compressor on Tunnel Work (low pressure); Asphalt Plant Engineer (Portage and Summit Counties Only); Bobcat-type and/or Skid Steer Loader with or without Attachments; Highway Drills (all types); Locomotive (narrow gauge); Material Hoist/Elevator; Mixer, Concrete (more than one bag capacity); Mixer, one bag capacity (Side Loader); Power Boiler (Over 15 lbs. Pressure) Pump Operator installing & operating Well Points; Pump (4" & over discharge); Roller, Asphalt; Rotovator (lime soil stabilizer); Switch & Tie Tampers (without lifting & aligning device); Utility Operator (Small equipment); Welding Machines; and Railroad Tie Inserter/Remover; Articulating/straight bed end dumps if assigned (minus \$4.00 per hour).

GROUP 4 - Backfiller; Ballast Re-locator; Bars, Joint & Mesh Installing Machine; Batch Plant; Boring Machine Operator (48" or less); Bull Floats; Burlap & Curing Machine; Concrete Plant (capacity 4 yd. & under); Concrete Saw (Multiple); Conveyor (Highway); Crusher; Deckhand; Farm-type Tractor with attachments (highway); Finishing Machine; Fireperson, Floating Equipment (all types); Forklift; Form Trencher; Hydro Hammer expect masonry; Hydro Seeder; Pavement Breaker; Plant Mixer; Post Driver; Post Hole Digger (Power Auger); Power Brush Burner; Power Form Handling Equipment; Road Widening Trencher; Roller (Brick, Grade & Macadam); Self-Propelled Power Spreader; Self-Propelled Power Subgrader; Steam Fireperson; Tractor (Pulling Sheepfoot, Roller or Grader); and Vibratory Compactor with Integral Power.

GROUP 5 - Compressor (Portable, Sewer, Heavy & Highway); Drum Fireperson (Asphalt Plant); Generator; Masonry Fork Lift; Inboard-Outboard Motor Boat Launch; Oil Heater (asphalt plant); Oiler/Helper; Power Driven Heater; Power Sweeper & Scrubber; Pump (under 4" discharge); Signaller; Tire Repairperson; VAC/ALLS; Cranes - Compact, track or rubber under 4,000 pound capacity; fueling and greasing; and Chainmen.

GROUP 6 - Master Mechanic & Boom from 150 to 180.

GROUP 7 - Boom from 180 and over.

ENGI0018-004 05/01/2019

ADAMS, ALLEN, ASHLAND, ATHENS, AUGLAIZE, BELMONT, BROWN, BUTLER, CARROLL, CHAMPAIGN, CLARK, CLERMONT, CLINTON, COSHOCTON, CRAWFORD, DARKE, DEFIANCE, DELAWARE, FAIRFIELD, FAYETTE, FRANKLIN, FULTON, GALLIA, GREENE, GUERNSEY, HAMILTON, HANCOCK, HARDIN, HARRISON, HENRY, HIGHLAND, HOCKING, HOLMES, HURON, JACKSON, JEFFERSON, KNOX, LAWRENCE, LICKING, LOGAN, LUCAS, MADISON, MARION, MEIGS, MERCER, MIAMI, MONROE, MONTGOMERY, MORGAN, MORROW, MUSKINGUM, NOBLE, OTTAWA, PAULDING, PERRY, PICKAWAY, PIKE, PREBLE, PUTNAM, RICHLAND, ROSS, SANDUSKY, SCIOTO, SENECA, SHELBY, STARK, TUSCARAWAS, UNION, VAN WERT, VINTON, WARREN, WASHINGTON, WAYNE, WILLIAMS, WOOD, and YANDOT COUNTIES

POWER EQUIPMENT OPERATOR

GROUP 1.....	\$ 37.14	15.20
GROUP 2.....	\$ 37.02	15.20
GROUP 3.....	\$ 35.98	15.20
GROUP 4.....	\$ 34.80	15.20
GROUP 5.....	\$ 29.34	15.20
GROUP 6.....	\$ 37.39	15.20
GROUP 7.....	\$ 37.64	15.20

OPERATING ENGINEER CLASSIFICATIONS

GROUP 1 - Air Compressor on Steel Erection; Barrier Moving Machine; Boiler Operator on Compressor or Generator when mounted on a Rig; Cableway; Combination Concrete Mixer & Tower; Concrete Plant (over 4 yd. Capacity); Concrete Pump; Crane (All Types, Including Boom Truck, Cherry Picker); Crane-Compact, Track or Rubber over 4,000 lbs. capacity; Cranes-Self Erecting, Stationary, Track or Truck (All Configurations); Derrick; Dragline; Dredge (Dipper, Clam or Suction); Elevating Grader or Euclid Loader; Floating Equipment (All Types); Gradall; Helicopter Crew (Operator-Hoist or Winch); Hoe (all types); Hoisting Engine on Shaft or Tunnel Work; Hydraulic Gantry (Lifting System); Industrial-Type Tractor; Jet Engine Dryer (D8 or D9) Diesel Tractor; Locomotive (Standard Gauge); Maintenance Operator Class A; Mixer, Paving (Single or Double Drum); Mucking Machine; Multiple Scraper; Piledriving Machine (All Types); Power Shovel; Prentice Loader; Quad 9 (Double Pusher); Rail Tamper (with auto lifting & aligning device); Refrigerating Machine (Freezer Operation); Rotary Drill, on Caisson work; Rough Terrain Fork Lift with Winch/Hoist; Side-Boom; Slip-Form Paver; Tower Derrick; Tree Shredder; Trench Machine (Over 24" wide); Truck Mounted Concrete Pump; Tug Boat; Tunnel Machine and/or Mining Machine; and Wheel Excavator.

GROUP 2 - Asphalt Paver; Automatic Subgrader Machine, Self-Propelled (CMI Type); Bobcat Type and/or Skid Steer Loader with Hoe Attachment Greater than 7,000 lbs.; Boring Machine More than 48"; Bulldozer; Endloader; Hydro Milling Machine; Horizontal Directional Drill (over 50,000 ft. lbs. thrust); Kolman-type Loader (production type-Dirt); Lead Greaseman; Lighting & Traffic Signal Installation Equipment (includes all groups or classifications); Material Transfer Equipment (Shuttle Buggy) Asphalt; Pettibone-Rail Equipment; Power Grader; Power Scraper; Push Cat; Rotomill (all), Grinders & Planers of All types; Trench Machine (24" wide & under); and Vermeer type Concrete Saw.

GROUP 3 - A-Frame; Air Compressor on Tunnel Work (low pressure); Asphalt Plant Engineer; Bobcat-type and/or Skid Steer Loader with or without Attachments; Highway Drills (all types); Locomotive (narrow gauge); Material Hoist/Elevator; Mixer, Concrete (more than one bag capacity); Mixer, one bag capacity (Side Loader); Power Boiler (Over 15 lbs. Pressure) Pump Operator installing & operating Well Points; Pump (4" & over discharge); Railroad Tie Inserter/Remover; Roller, Asphalt; Rotovator (lime soil stabilizer); Switch & Tie Tampers (without lifting & aligning device); Utility Operator (Small equipment); and Welding Machines; Articulating/straight bed end dumps if assigned (minus \$4.00 per hour).

GROUP 4 - Backfiller; Ballast Re-locator; Bars, Joint & Mesh Installing Machine; Batch Plant; Boring Machine Operator (48" or less); Bull Floats; Burlap & Curing Machine; Concrete Plant (capacity 4 yd. & under); Concrete Saw (Multiple); Conveyor (Highway); Crusher; Deckhand; Farm-type Tractor with attachments (highway); Finishing

Machine; Fireperson, Floating Equipment (all types); Fork Lift; Form Trencher; Hydro Hammer expect masonry; Hydro Seeder; Pavement Breaker; Plant Mixer; Post Driver; Post Hole Digger (Power Auger); Power Brush Burner; Power Form Handling Equipment; Road Widening Trencher; Roller (Brick, Grade & Macadam); Self-Propelled Power Spreader; Self-Propelled Power Subgrader; Steam Fireperson; Tractor (Pulling Sheepfoot, Roller or Grader); and Vibratory Compactor with Integral Power.

GROUP 5 - Compressor (Portable, Sewer, Heavy & Highway); Drum Fireperson (Asphalt Plant); Generator; Masonary Forklift; Inboard-Outboard Motor Boat Launch; Oil Heater (asphalt plant); Oiler/Helper; Power Driven Heater; Power Sweeper & Scrubber; Pump (under 4" discharge); Signalperson; Tire Repairperson; VAC/ALLS; Cranes - Compact, track or rubber under 4,000 pound capacity; fueling and greasing; and Chainmen.

GROUP 6 - Master Mechanic & Boom from 150 to 180.

GROUP 7 - Boom from 180 and over.

 ENGI0066-023 06/01/2017

COLUMBIANA, MAHONING & TRUMBULL COUNTIES

	Rates	Fringes
POWER EQUIPMENT OPERATOR		
ASBESTOS; HAZARDOUS/TOXIC WASTE PROJECTS		
GROUP 1 - A & B.....	\$ 39.23	19.66
ASBESTOS; HAZARDOUS/TOXIC WASTE PROJECTS		
GROUP 2 - A & B.....	\$ 38.90	19.66
ASBESTOS; HAZARDOUS/TOXIC WASTE PROJECTS		
GROUP 3 - A & B.....	\$ 34.64	19.66
ASBESTOS; HAZARDOUS/TOXIC WASTE PROJECTS		
GROUP 4 - A & B.....	\$ 30.70	19.66
ASBESTOS; HAZARDOUS/TOXIC WASTE PROJECTS		
GROUP 5 - A & B.....	\$ 27.30	19.66
HAZARDOUS/TOXIC WASTE PROJECTS		
GROUP 1 - C & D.....	\$ 35.96	19.66
HAZARDOUS/TOXIC WASTE PROJECTS		
GROUP 2 - C & D.....	\$ 35.66	19.66
HAZARDOUS/TOXIC WASTE PROJECTS		
GROUP 3 - C & D.....	\$ 31.76	19.66
HAZARDOUS/TOXIC WASTE PROJECTS		
GROUP 4 - C & D.....	\$ 28.14	19.66
HAZARDOUS/TOXIC WASTE PROJECTS		
GROUP 5 - C & D.....	\$ 25.03	19.66
ALL OTHER WORK		
GROUP 1.....	\$ 32.69	19.66
ALL OTHER WORK		
GROUP 2.....	\$ 32.42	19.66
ALL OTHER WORK		
GROUP 3.....	\$ 28.87	19.66
ALL OTHER WORK		
GROUP 4.....	\$ 25.58	19.66
ALL OTHER WORK		

GROUP 1 - Rig, Pile Driver or Caisson Type; & Rig, Pile Hydraulic Unit Attached

GROUP 2 - Asphalt Heater Planer; Backfiller with Drag Attachment; Backhoe; Backhoe with Shear attached; Backhoe-Rear Pivotal Swing; Batch Plant-Central Mix Concrete; Batch Plant, Portable concrete; Berm Builder-Automatic; Boat Derrick; Boat-Tug; Boring Machine Attached to Tractor; Bullclam; Bulldozer; C.M.I. Road Builder & Similar Type; Cable Placer & Layer; Carrier-Straddle; Carryall-Scraper or Scoop; Chicago Boom; Compactor with Blade Attached; Concrete Saw (Vermeer or similar type); Concrete Spreader Finisher; Combination, Bidwell Machine; Crane; Crane-Electric Overhead; Crane-Rough Terrain; Crane-Side Boom; Crane-Truck; Crane-Tower; Derrick-Boom; Derrick-Car; Digger-Wheel (Not trencher or road widener); Double Nine; Drag Line; Dredge; Drill-Kenny or Similar Type; Easy Pour Median Barrier Machine (or similar type); Electromatic; Frankie Pile; Gradall; Grader; Gurry; Self-Propelled; Heavy Equipment Robotics Operator/Mechanic; Hoist-Monorail; Hoist-Stationary & Mobile Tractor; Hoist, 2 or 3 drum; Horizontal Directional Drill Operator; Jackall; Jumbo Machine; Kocal & Kuhlman; Land-Seagoing Vehicle; Loader, Elevating; Loader, Front End; Loader, Skid Steer; Locomotive; Mechanic/Welder; Metro Chip Harvester with Boom; Mucking Machine; Paver-Asphalt Finishing Machine; Paver-Road Concrete; Paver-Slip Form (C.M.I. or similar); Place Crete Machine with Boom; Post Driver (Carrier mounted); Power Driven Hydraulic Pump & Jack (When used in Slip Form or Lift Slab Construction); Pump Crete Machine; Regulator-Ballast; Hydraulic Power Unit not attached to Rig for Pile Drillings; Rigs-Drilling; Roto Mill or similar Full Lane (8' Wide & Over); Roto Mill or similar type (Under 8'); Shovel; Slip Form Curb Machine; Speedwing; Spikemaster; Stonecrusher; Tie Puller & Loader; Tie Tamper; Tractor-Double Boom; Tractor with Attachments; Truck-Boom; Truck-Tire; Trench Machine; Tunnel Machine (Mark 21 Java or similar); & Whirley (or similar type)

GROUP 3 - Asphalt Plant; Bending Machine (Pipeline or similar type); Boring machine, Motor Driven; Chip Harvester without Boom; Cleaning Machine, Pipeline Type; Coating Machine, Pipeline Type; Compactor; Concrete Belt Placer; Concrete Finisher; Concrete Planer or Asphalt; Concrete Spreader; Elevator; Fork Lift (Home building only); Fork lift & Lulls; Fork Lift Walk Behind (Hoisting over 1 buck high); Form Line Machine; Grease Truck operator; Grout Pump; Gunnite Machine; Horizontal Directional Drill Locator; Single Drum Hoist with or without Tower; Huck Bolting Machine; Hydraulic Scaffold (Hoisting building materials); Paving Breaker (Self-propelled or Ridden); Pipe Dream; Pot Fireperson (Power Agitated); Refrigeration Plant; Road Widener; Roller; Sasgen Derrick; Seeding Machine; Soil Stabilizer (Pump type); Spray Cure Machine, Self-Propelled; Straw Blower Machine; Sub-Grader; Tube Finisher or Broom C.M.I. or similar type; & Tugger Hoist

GROUP 4 - Air Curtain Destructor & Similar Type; Batch Plant-Job Related; Boiler Operator; Compressor; Conveyor; Curb Builder, self-propelled; Drill Wagon; Generator Set; Generator-Steam; Heater-Portable Power; Hydraulic Manipulator Crane; Jack-Hydraulic Power driven; Jack-Hydraulic (Railroad); Ladavator; Minor Machine Operator; Mixer-Concrete; Mulching Machine; Pin Puller; Power Broom; Pulverizer; Pump; Road Finishing Machine (Pull Type); Saw-Concrete-Self-Propelled (Highway Work); Signal Person; Spray Cure Machine-Motor Powered; Stump Cutter;

Tractor; Trencher Form; Water Blaster; Steam Jenny;
Syphon; Vibrator-Gasoline; & Welding Machine

GROUP 5 - Brakeperson; Fireperson; & Oiler

IRON0017-002 05/01/2023

ASHTABULA (North of Route 6, starting at the Geauga County Line, proceeding east to State Route 45), CUYAHOGA, ERIE (Eastern 2/3), GEAUGA, HURON (East of a line drawn from the north border through Monroeville & Willard), LAKE, LORAIN, MEDINA (North of Old Rte. #224), PORTAGE (West of a line from Middlefield to Shalersville to Deerfield), and SUMMIT (North of Old Rte. #224, including city limits of Barberton) COUNTIES

Rates Fringes

IRONWORKER
Ornamental, Reinforcing, &
Structural.....\$ 35.83 28.01

IRON0017-010 05/01/2023

ASHTABULA (Eastern part from Lake Erie on the north to route #322 on the south to include Conneaut, Kingsville, Sheffield, Denmark, Dorset, Cherry Valley, Wayne, Monroe, Pierpont, Richmond, Andover & Williamsfield Townships)

Rates Fringes

IRONWORKER
Structural, including
metal building erection &
Reinforcing.....\$ 35.83 28.01

IRON0044-001 06/01/2022

ADAMS (Western Part), BROWN, BUTLER (Southern Part), CLERMONT, CLINTON (South of a line drawn from Blanchester to Lynchburg), HAMILTON, HIGHLAND (Excluding eastern one-fifth & portion of county inside lines drawn from Marshall to Lynchburg from the northern county line through E. Monroe to Marshall) and WARREN (South of a line drawn from Blanchester through Morrow to the west county line) COUNTIES

Rates Fringes

IRONWORKER, REINFORCING.....\$ 32.37 22.30
Beyond 30-mile radius of
Hamilton County Courthouse..\$ 28.67 21.20
Up to & including 30-mile
radius of Hamilton County
Courthouse.....\$ 27.60 20.70

IRON0044-002 06/01/2023

CLINTON (South of a line drawn from Blanchester to Lynchburg), HAMILTON, HIGHLAND (Excluding eastern one-fifth & portion of county inside lines drawn from Marshall to Lynchburg from the northern county line through E. Monroe to Marshall) & WARREN (South of a line drawn from Blanchester through Morrow to the west county line)

Rates Fringes

IRONWORKER		
Fence Erector.....	\$ 30.75	23.30
Ornamental; Structural.....	\$ 32.37	23.30

 IRON0055-003 07/01/2023

CRAWFORD (Area Between lines drawn from where Hwy #598 & #30 meet through N. Liberty to the northern border & from said Hwy junction point due west to the border), DEFIANCE (S. of a line drawn from where Rte. #66 meets the northern line through Independence to the eastern county border), ERIE (Western 1/3), FULTON, HANCOCK, HARDIN (North of a line drawn from Maysville to a point 4 miles south of the northern line on the eastern line), HENRY, HURON (West of a line drawn from the northern border through Monroeville & Willard), LUCAS, OTTAWA, PUTNAM (East of a line drawn from the northern border down through Miller City to where #696 meets the southern border), SANDUSKY, SENECA, WILLIAMS (East of a line drawn from Pioneer through Stryker to the southern border), WOOD & WYANDOT (North of Rte. #30)

	Rates	Fringes
IRONWORKER		
Fence Erector.....	\$ 25.40	23.87
Flat Road Mesh.....	\$ 29.77	21.30
Tunnels & Caissons Under Pressure.....	\$ 29.77	21.30
All Other Work.....	\$ 34.25	28.20

 IRON0147-002 06/01/2023

ALLEN (Northern half), DEFIANCE (Northern part, excluding south of a line drawn from where Rte. #66 meets the northern line through Independence to the eastern county border), MERCER (Northern half), PAULDING, PUTNAM (Western part, excluding east of a line drawn from the northern border down through Miller City to where #696 meets the southern border), VAN WERT, and WILLIAMS (Western part, excluding east of a line drawn from Pioneer through Stryker to the southern border) COUNTIES

	Rates	Fringes
IRONWORKER.....	\$ 33.00	25.59

 IRON0172-002 06/01/2023

CHAMPAIGN (Eastern one-third), CLARK (Eastern one-fourth), COSHOCTON (West of a line beginning at the northwestern county line going through Walhonding & Tunnel Hill to the southern county line), CRAWFORD (South of Rte. #30), DELAWARE, FAIRFIELD, FAYETTE, FRANKLIN, HARDIN (Excluding a line drawn from Roundhead to Maysville), HIGHLAND (Eastern one-fifth), HOCKING, JACKSON (Northern half), KNOX, LICKING, LOGAN (Eastern one-third), MADISON, MARION, MORROW, MUSKINGUM (West of a line starting at Adams Mill going to Adamsville & going from Adamsville through Blue Rock to the southern border), PERRY, PICKAWAY, PIKE (Northern half), ROSS, UNION, VINTON and WYANDOT (South of Rte. #30) COUNTIES

	Rates	Fringes
IRONWORKER.....	\$ 34.07	22.55

 IRON0207-004 06/01/2023

ASHTABULA (Southern part starting at the Geauga County line),

COLUMBIANA (E. of a line from Damascus to Highlandtown), MAHONING (N. of Old Route #224), PORTAGE (E. of a line from Middlefield to Shalersville to Deerfield) & TRUMBULL

Rates Fringes

IRONWORKER		
Layout; Sheeter.....	\$ 34.00	27.16
Ornamental; Reinforcing;		
Structural.....	\$ 33.00	27.16
Ornamental; Reinforcing.....	\$ 28.92	25.61

IRON0290-002 06/01/2023

ALLEN (Southern half), AUGLAIZE, BUTLER (North of a line drawn from east to the west county line going through Oxford, Darrtown & Woodsdale), CHAMPAIGN (Excluding east of a line drawn from Catawla to the point where #68 intersects the northern county line), CLARK (Western two-thirds), CLINTON (Excluding south of a line drawn from Blanchester to Lynchburg), DARKE, GREENE, HIGHLAND (Inside lines drawn from Marshall to Lynchburg & from the northern county line through East Monroe to Marshall), LOGAN (West of a line drawn from West Liberty to where the northern county line meets the western county line of Hardin), MERCER (Southern half), MIAMI, MONTGOMERY, PREBLE, SHELBY & WARREN (Excluding south of a line drawn from Blanchester through Morrow to the western county line) COUNTIES

Rates Fringes

IRONWORKER.....	\$ 32.69	24.05
-----------------	----------	-------

IRON0549-003 12/01/2022

BELMONT, GUERNSEY, HARRISON, JEFFERSON, MONROE & MUSKINGUM (Excluding portion west of a line starting at Adams Mill going to Adamsville and going from Adamsville through Blue Rock to the south border)

Rates Fringes

IRONWORKER.....	\$ 35.19	25.66
-----------------	----------	-------

IRON0550-004 05/01/2023

ASHLAND, CARROLL, COLUMBIANA (W. of a line from Damascus to Highlandtown), COSHOCTON (E. of a line beginning at NW Co. line going through Walhonding & Tunnel Hill to the South Co. line), HOLMES, HURON (S. of Old Rte. #224), MAHONING (S. of Old Rte. #224), MEDINA (S. of Old Rte. #224), PORTAGE (S. of Old Rte. #224), RICHLAND, STARK, SUMMIT (S. of Old Rte. #224, Excluding city limits of Barberton), TUSCARAWAS, & WAYNE

Rates Fringes

Ironworkers:Structural, Ornamental and Reinforcing.....	\$ 33.00	22.27
--	----------	-------

IRON0769-004 06/01/2023

ADAMS (Eastern Half), GALLIA, JACKSON (Southern Half), LAWRENCE & SCIOTO

Rates Fringes

IRONWORKER.....\$ 36.16 28.34

IRON0787-003 12/01/2023

ATHENS, MEIGS, MORGAN, NOBLE, and WASHINGTON COUNTIES

Rates Fringes
IRONWORKER.....\$ 33.30 23.95

LABO0265-008 05/01/2023

Rates Fringes

LABORER

ASHTABULA, ERIE, HURON,
LORAIN, LUCAS, MAHONING,
MEDINA, OTTAWA, PORTAGE,
SANDUSKY, STARK, SUMMIT,
TRUMBULL & WOOD COUNTIES

GROUP 1.....\$ 35.05 13.70
GROUP 2.....\$ 35.22 13.70
GROUP 3.....\$ 35.55 13.70
GROUP 4.....\$ 36.00 13.70

CUYAHOGA AND GEAUGA
COUNTIES ONLY: SEWAGE
PLANTS, WASTE PLANTS,
WATER TREATMENT
FACILITIES, PUMPING
STATIONS, & ETHANOL PLANTS

CONSTRUCTION.....\$ 37.66 13.70

CUYAHOGA, GEAUGA & LAKE
COUNTIES

GROUP 1.....\$ 36.28 13.70
GROUP 2.....\$ 36.45 13.70
GROUP 3.....\$ 36.78 13.70
GROUP 4.....\$ 37.23 13.70

REMAINING COUNTIES OF OHIO

GROUP 1.....\$ 34.62 13.70
GROUP 2.....\$ 34.79 13.70
GROUP 3.....\$ 35.12 13.70
GROUP 4.....\$ 35.57 13.70

LABORER CLASSIFICATIONS

GROUP 1 - Asphalt Laborer; Carpenter Tender; Concrete Curing
Applicator; Dump Man (Batch Truck); Guardrail and Fence
Installer; Joint Setter; Laborer (Construction); Landscape
Laborer; Mesh Handlers & Placer; Right-of-way Laborer;
Riprap Laborer & Grouter; Scaffold Erector; Seal Coating;
Surface Treatment or Road Mix Laborer; Sign Installer;
Slurry Seal; Utility Man; Bridge Man; Handyman;
Waterproofing Laborer; Flagperson; Hazardous Waste (level
D); Diver Tender; Zone Person & Traffic Control

GROUP 2 - Asphalt Raker; Concrete Puddler; Kettle Man
Pipeline); Machine Driven Tools (Gas, Electric, Air); Mason
Tender; Brick Paver; Mortar Mixer; Power Buggy or Power
Wheelbarrow; Paint Striper; Sheeting & Shoring Man; Surface
Grinder Man; Plastic Fusing Machine Operator; Pug Mill
Operator; & Vacuum Devices (wet or dry); Rodding Machine
Operator; Diver; Screwman or Paver; Screed Person; Water
Blast, Hand Held Wand; Pumps 4" & Under (Gas, Air or
Electric) & Hazardous Waste (level C); Air Track and Wagon
Drill; Bottom Person; Cofferdam (below 25 ft. deep);
Concrete Saw Person; Cutting with Burning Torch; Form
Setter; Hand Spiker (Railroad); Pipelayer; Tunnel Laborer
(without air) & Caisson; Underground Person (working in
Sewer and Waterline, Cleaning, Repairing & Reconditioning);

Sandblaster Nozzle Person; & Hazardous Waste (level B)

GROUP 3 - Blaster; Mucker; Powder Person; Top Lander; Wrencher (Mechanical Joints & Utility Pipeline); Yarnier; Hazardous Waste (level A); Concrete Specialist; Concrete Crew in Tunnels (With Air-pressurized - \$1.00 premium); Curb Setter & Cutter; Grade Checker; Utility Pipeline Tapper; Waterline; and Caulker

GROUP 4 - Miner (With Air-pressurized - \$1.00 premium); & Gunite Nozzle Person

TUNNEL LABORER WITH AIR-PRESSURIZED ADD \$1.00 TO BASE RATE

SIGNAL PERSON WILL RECEIVE THE RATE EQUAL TO THE RATE PAID THE LABORER CLASSIFICATION FOR WHICH HE OR SHE IS SIGNALING.

PAIN0006-002 05/01/2023

ASHTABULA, CUYAHOGA, GEAUGA, LAKE, LORAIN, PORTAGE (N. of the East-West Turnpike) & SUMMIT (N. of the East-West Turnpike)

Rates Fringes

PAINTER

COMMERCIAL NEW WORK;
REMODELING; & RENOVATIONS

GROUP 1.....	\$ 30.75	18.95
GROUP 2.....	\$ 31.15	18.95
GROUP 3.....	\$ 31.45	18.95
GROUP 4.....	\$ 37.01	18.95

COMMERCIAL REPAINT

GROUP 1.....	\$ 29.25	18.95
GROUP 2.....	\$ 29.65	18.95
GROUP 3.....	\$ 29.95	18.95

PAINTER CLASSIFICATIONS - COMMERCIAL NEW WORK; REMODELING; & RENOVATIONS

GROUP 1 - Brush; & Roller

GROUP 2 - Sandblasting & Buffing

GROUP 3 - Spray Painting; Closed Steel Above 55 feet; Bridges & Open Structural Steel; Tanks - Water Towers; Bridge Painters; Bridge Riggers; Containment Builders

GROUP 4 - Bridge Blaster

PAINTER CLASSIFICATIONS - COMMERCIAL REPAINT

GROUP 1 - Brush; & Roller

GROUP 2 - Sandblasting & Buffing

GROUP 3 - Spray Painting

PAIN0007-002 07/01/2023

FULTON, HENRY, LUCAS, OTTAWA (Excluding Allen, Bay, Bono, Catawba Island, Clay Center, Curtice, Danbury, Eagle Beach, Elliston, Elmore, Erie, Fishback, Gem Beach & Genova) & WOOD

Rates Fringes

PAINTER

NEW COMMERCIAL WORK

GROUP 1.....	\$ 28.59	20.04
GROUP 2.....	\$ 29.59	20.04
GROUP 3.....	\$ 29.59	20.04
GROUP 4.....	\$ 29.59	20.04
GROUP 5.....	\$ 29.59	20.04
GROUP 6.....	\$ 29.59	20.04
GROUP 7.....	\$ 29.59	20.04
GROUP 8.....	\$ 29.59	20.04
GROUP 9.....	\$ 29.59	20.04

REPAINT IS 90% OF JR

PAINTER CLASSIFICATIONS

- GROUP 1 - Brush; Spray & Sandblasting Pot Tender
- GROUP 2 - Refineries & Refinery Tanks; Surfaces 30 ft. or over where material is applied to or labor performed on above ground level (exterior), floor level (interior)
- GROUP 3 - Swing Stage & Chair
- GROUP 4 - Lead Abatement
- GROUP 5 - All Methods of Spray
- GROUP 6 - Solvent-Based Catalized Epoxy Materials of 2 or More Component Materials, to include Solvent-Based Conversion Varnish (excluding water based)
- GROUP 7 - Spray Solvent Based Material; Sand & Abrasive Blasting
- GROUP 8 - Towers; Tanks; Bridges; Stacks Over 30 Feet
- GROUP 9 - Epoxy Spray (excluding water based)

PAIN0012-008 05/01/2019

BUTLER COUNTY

	Rates	Fringes
PAINTER		
GROUP 1.....	\$ 21.95	10.20
GROUP 2.....	\$ 25.30	10.20
GROUP 3.....	\$ 25.80	10.20
GROUP 4.....	\$ 26.05	10.20
GROUP 5.....	\$ 26.30	10.20

PAINTER CLASSIFICATIONS

- GROUP 1: Bridge Equipment Tender; Bridge/Containment Builder
- GROUP 2: Brush & Roller
- GROUP 3: Spray
- GROUP 4: Sandblasting; & Waterblasting
- GROUP 5: Elevated Tanks; Steeplejack Work; Bridge; & Lead Abatement

PAIN0012-010 05/01/2019

BROWN, CLERMONT, CLINTON, HAMILTON & WARREN

Rates Fringes

PAINTER

HEAVY & HIGHWAY BRIDGES-
GUARDRAILS-LIGHTPOLES-
STRIPING

Bridge Equipment Tender and Containment Builder....	\$ 21.95	10.20
Bridges when highest point of clearance is 60 feet or more; & Lead		
Abatement Projects.....	\$ 26.30	10.20
Brush & Roller.....	\$ 25.30	10.20
Sandblasting & Hopper Tender; Water Blasting.....	\$ 26.05	10.20
Spray.....	\$ 25.80	10.20

PAIN0093-001 12/01/2023

ATHENS, GUERNSEY, HOCKING, MONROE, MORGAN, NOBLE and
WASHINGTON COUNTIES

Rates Fringes

PAINTER

Bridges; Locks; Dams; Tension Towers; & Energized Substations.....	\$ 35.45	23.69
Power Generating Facilities.	\$ 32.30	23.69

PAIN0249-002 05/01/2023

CLARK, DARKE, GREENE, MIAMI, MONTGOMERY & PREBLE

Rates Fringes

PAINTER

GROUP 1 - Brush & Roller....	\$ 26.23	12.56
GROUP 2 - Swing, Scaffold Bridges; Structural Steel; Open Acid Tank; High Tension Electrical Equipment; & Hot Pipes.....	\$ 26.23	12.56
GROUP 3 - Spray; Sandblast; Steamclean; Lead Abatement.....	\$ 26.98	12.56
GROUP 4 - Steeplejack Work..	\$ 27.18	12.56
GROUP 5 - Coal Tar.....	\$ 27.73	12.56
GROUP 6 - Bridge Equipment Tender & or Containment Builder.....	\$ 34.94	12.56
GROUP 7 - Tanks, Stacks & Towers.....	\$ 29.87	12.56
GROUP 8 - Bridge Blaster, Rigger.....	\$ 37.94	12.56

PAIN0356-002 09/01/2009

KNOX, LICKING, MUSKINGUM, and PERRY

Rates Fringes

PAINTER

Bridge Equipment Tenders and Containment Builders....	\$ 27.93	7.25
Bridges; Blasters; and Riggers.....	\$ 34.60	7.25
Brush and Roller.....	\$ 20.93	7.25

Sandblasting; Steam Cleaning; Waterblasting; and Hazardous Work.....	\$ 25.82	7.25
Spray.....	\$ 21.40	7.25
Structural Steel and Swing Stage.....	\$ 25.42	7.25
Tanks; Stacks; and Towers...	\$ 28.63	7.25

PAIN0438-002 12/01/2023

BELMONT, HARRISON and JEFFERSON COUNTIES

	Rates	Fringes
PAINTER		
Bridges, Locks, Dams, Tension Towers & Energized Substations.....	\$ 36.09	19.49
Power Generating Facilities.	\$ 32.94	19.49

PAIN0476-001 06/01/2023

COLUMBIANA, MAHONING, and TRUMBULL COUNTIES

	Rates	Fringes
PAINTER		
GROUP 1.....	\$ 27.49	17.06
GROUP 2.....	\$ 34.12	17.06
GROUP 3.....	\$ 27.70	17.06
GROUP 4.....	\$ 27.99	17.06
GROUP 5.....	\$ 28.14	17.06
GROUP 6.....	\$ 28.39	17.06
GROUP 7.....	\$ 29.49	17.06

PAINTER CLASSIFICATIONS:

- GROUP 1: Painters, Brush & Roller
- GROUP 2: Bridges
- GROUP 3: Structural Steel
- GROUP 4: Spray, Except Bar Joist/Deck
- GROUP 5: Epoxy/Mastic; Spray- Bar Joist/Deck; Working Above 50 Feet; and Swingstages
- GROUP 6: Tanks; Sandblasting
- GROUP 7: Towers; Stacks

PAIN0555-002 11/01/2023

ADAMS, HIGHLAND, JACKSON, PIKE & SCIOTO

	Rates	Fringes
PAINTER		
GROUP 1.....	\$ 32.18	20.29
GROUP 2.....	\$ 33.81	20.29
GROUP 3.....	\$ 35.44	20.29
GROUP 4.....	\$ 38.63	20.29

PAINTER CLASSIFICATIONS

- GROUP 1 - Containment Builder
- GROUP 2 - Brush; Roller; Power Tools, Under 40 feet

GROUP 3 - Sand Blasting; Spray; Steam Cleaning; Pressure Washing; Epoxy & Two Component Materials; Lead Abatement; Hazardous Waste; Toxic Materials; Bulk & Storage Tanks of 25,000 Gallon Capacity or More; Elevated Tanks

GROUP 4 - Stacks; Bridges

 PAIN0639-001 05/01/2011

	Rates	Fringes
Sign Painter & Erector.....	\$ 20.61	3.50+a+b+c

FOOTNOTES: a. 7 Paid Holidays: New Year's Day; Memorial Day; July 4th; Labor Day; Thanksgiving Day; Christmas Day & 1 Floating Day

b. Vacation Pay: After 1 year's service - 5 days' paid vacation; After 2, but less than 10 years' service - 10 days' paid vacation; After 10, but less than 20 years' service - 15 days' paid vacation; After 20 years' service - 20 days' paid vacation

c. Funeral leave up to 3 days maximum paid leave for death of mother, father, brother, sister, spouse, child, mother-in-law, father-in-law, grandparent and inlaw provided employee attends funeral

 PAIN0788-002 06/01/2023

ASHLAND, CRAWFORD, ERIE, HANCOCK, HURON, MARION, MORROW, OTTAWA (Allen, Bay, Bono, Catawba Island, Clay Center, Curtice, Danbury, Eagle Beach, Elliston, Elmore, Erie, Fishback, Gem Beach & Genoa), RICHLAND, SANDUSKY, SENECA & WYANDOT

	Rates	Fringes
PAINTER		
Brush & Roller.....	\$ 25.78	17.12
Structural Steel.....	\$ 27.38	17.12

WINTER REPAINT: Between December 1 to March 31 - 90%JR

\$.50 PER HOUR SHALL BE ADDED TO THE RATE OF PAY FOR THE CLASSIFICATION OF WORK:

While working swingstage, boatswain chair, needle beam and horizontal cable. While operating sprayguns, sandblasting, cobblasting and high pressure waterblasting (4000psi).

\$1.00 PER HOUR SHALL BE ADDED TO THE RATE OF PAY FOR THE CLASSIFICATION OF WORK:

For the application of catalized epoxy, including latex epoxy that is deemed hazardous, lead abatement, or for work or material where special precautions beyond normal work duties must be taken. For working on stacks, tanks, and towers over 40 feet in height.

 PAIN0813-005 12/01/2008

GALLIA, LAWRENCE, MEIGS & VINTON

	Rates	Fringes
PAINTER		
Base Rate.....	\$ 24.83	10.00

Bridges, Locks, Dams &
Tension Towers.....\$ 27.83 10.00

PAIN0841-001 06/01/2023

MEDINA, PORTAGE (South of and including Ohio Turnpike), and
SUMMIT (South of and including Ohio Turnpike) COUNTIES

	Rates	Fringes
Painters:		
GROUP 1.....	\$ 30.18	15.50
GROUP 2.....	\$ 30.83	15.50
GROUP 3.....	\$ 30.93	15.50
GROUP 4.....	\$ 31.03	15.50
GROUP 5.....	\$ 31.43	15.50
GROUP 6.....	\$ 39.20	11.75
GROUP 7.....	\$ 31.68	15.50

PAINTER CLASSIFICATIONS:

GROUP 1 - Brush, Roller & Paperhanger

GROUP 2 - Epoxy Application

GROUP 3 - Swing Scaffold, Bosum Chair, & Window Jack

GROUP 4 - Spray Gun Operator of Any & All Coatings

GROUP 5 - Sandblast, Painting of Standpipes, etc. from
Scaffolds, Bridge Work and/or Open Structural Steel,
Standpipes and/or Water Towers

GROUP 6 - Public & Commerce Transportation, Steel or
Galvanized, Bridges, Tunnels & Related Support Items
(concrete)

GROUP 7 - Synthetic Exterior, Drywall Finisher and/or Taper,
Drywall Finisher and Follow-up Man Using Automatic Tools

PAIN0841-002 06/01/2022

CARROLL, COSHOCTON, HOLMES, STARK, TUSCARAWAS & WAYNE

	Rates	Fringes
PAINTER		
Bridges; Towers, Poles & Stacks; Sandblasting Steel; Structural Steel & Metalizing.....	\$ 23.50	15.45
Brush & Roller.....	\$ 28.18	15.45
Spray; Tank Interior & Exterior.....	\$ 23.50	15.45

PAIN1020-002 07/01/2023

ALLEN, AUGLAIZE, CHAMPAIGN, DEFIANCE, HARDIN, LOGAN, MERCER,
PAULDING, PUTNAM, SHELBY, VAN WERT, and WILLIAMS COUNTIES

	Rates	Fringes
PAINTER		
Brush & Roller.....	\$ 26.64	15.56
Drywall Finishing & Taping..	\$ 27.39	15.56
Lead Abatement.....	\$ 28.39	15.56
Spray, Sandblasting		

Pressure Cleaning, & Refinery.....	\$ 27.39	15.56
Swing Stage, Chair, Spiders, & Cherry Pickers...	\$ 26.89	15.56
Wallcoverings.....	\$ 27.39	15.56

All surfaces 40 ft. or over where material is applied to or labor performed on, above ground level (exterior), floor level (interior) - \$.50 premium

Applying Coal Tar Products - \$1.00 premium

PAIN1275-002 11/01/2023

DELAWARE, FAIRFIELD, FAYETTE, FRANKLIN, MADISON, PICKAWAY, ROSS & UNION

	Rates	Fringes
PAINTER		
Bridges.....	\$ 35.01	15.16
Brush; Roller.....	\$ 29.40	15.16
Sandblasting; Steamcleaning; Waterblasting (3500 PSI or Over)& Hazardous Work.....	\$ 30.10	15.16
Spray.....	\$ 29.90	15.16
Stacks; Tanks; & Towers.....	\$ 32.21	15.16
Structural Steel & Swing Stage.....	\$ 28.25	15.16

PLAS0109-001 05/01/2023

MEDINA, PORTAGE, STARK, and SUMMIT COUNTIES

	Rates	Fringes
PLASTERER.....	\$ 33.74	19.02

PLAS0109-003 05/01/2023

CARROLL, HOLMES, TUSCARAWAS, and WAYNE COUNTIES

	Rates	Fringes
PLASTERER.....	\$ 33.74	19.02

PLAS0132-002 07/01/2023

BROWN, BUTLER, CLERMONT, HAMILTON, HIGHLAND, WARREN COUNTIES

	Rates	Fringes
PLASTERER.....	\$ 28.40	16.24

PLAS0404-002 05/01/2018

ASHTABULA, CUYAHOGA, GEAUGA, AND LAKE COUNTIES

	Rates	Fringes
PLASTERER.....	\$ 29.63	17.11

PLAS0404-003 05/01/2018

LORAIN COUNTY

	Rates	Fringes
--	-------	---------

PLASTERER.....\$ 28.86 17.11

PLAS0526-022 05/01/2018

COLUMBIANA, MAHONING, and TRUMBULL COUNTIES

Rates Fringes
PLASTERER.....\$ 28.86 17.11

PLAS0526-023 05/01/2018

BELMONT, HARRISON, and JEFFERSON COUNTIES

Rates Fringes
PLASTERER.....\$ 28.21 17.11

PLAS0886-001 05/01/2023

FULTON, HANCOCK, HENRY, LUCAS, PUTNAM, and WOOD COUNTIES

Rates Fringes
PLASTERER.....\$ 33.74 18.95

PLAS0886-003 05/01/2023

DEFIANCE, ERIE, HURON, OTTAWA, PAULDING, SANDUSKY, and SENECA COUNTIES

Rates Fringes
PLASTERER.....\$ 33.74 18.95

PLAS0886-004 05/01/2023

ALLEN, AUGLAIZE, HARDIN, LOGAN, MERCER, and VAN WERT COUNTIES

Rates Fringes
PLASTERER.....\$ 33.74 18.95

PLUM0042-002 07/01/2023

ASHLAND, CRAWFORD, ERIE, HURON, KNOX, LORAIN, MORROW, RICHLAND & WYANDOT

Rates Fringes
Plumber, Pipefitter,
Steamfitter.....\$ 37.62 25.47

PLUM0050-002 07/03/2023

DEFIANCE, FULTON, HANCOCK, HENRY, LUCAS, OTTAWA, PAULDING, PUTNAM, SANDUSKY, SENECA, WILLIAMS & WOOD

Rates Fringes
Plumber, Pipefitter,
Steamfitter.....\$ 47.15 30.21

PLUM0055-003 05/01/2023

ASHTABULA, CUYAHOGA, GEAUGA, LAKE, MEDINA (N. of Rte. #18 &

Smith Road) & SUMMIT (N. of Rte. #303, including the corporate limits of the city of Hudson)

	Rates	Fringes
PLUMBER.....	\$ 41.11	29.88

PLUM0083-001 07/01/2017

BELMONT & MONROE (North of Rte. #78)

	Rates	Fringes
Plumber and Steamfitter.....	\$ 32.16	31.51

PLUM0094-002 05/01/2023

CARROLL (Northen Half), STARK, and WAYNE COUNTIES

	Rates	Fringes
PLUMBER/PIPEFITTER.....	\$ 38.03	23.09

PLUM0120-002 05/01/2023

ASHTABULA, CUYAHOGA, GEAUGA, LAKE, LORAIN (the C.E.I. Power House in Avon Lake), MEDINA (N. of Rte. #18) & SUMMIT (N. of #303)

	Rates	Fringes
PIPEFITTER.....	\$ 45.62	27.30

PLUM0162-002 06/01/2023

CHAMPAIGN, CLARK, CLINTON, DARKE, FAYETTE, GREENE, MIAMI, MONTGOMERY & PREBLE

	Rates	Fringes
Plumber, Pipefitter, Steamfitter.....	\$ 40.00	26.87

PLUM0168-002 06/01/2023

MEIGS, MONROE (South of Rte. #78), MORGAN (South of Rte. #78) & WASHINGTON

	Rates	Fringes
PLUMBER/PIPEFITTER.....	\$ 38.95	34.97

PLUM0189-002 06/01/2022

DELAWARE, FAIRFIELD, FRANKLIN, HOCKING, LICKING, MADISON, MARION, PERRY, PICKAWAY, ROSS & UNION

	Rates	Fringes
Plumber, Pipefitter, Steamfitter.....	\$ 43.25	26.94

PLUM0219-002 06/01/2023

MEDINA (Rte. #18 from eastern edge of Medina Co., west to

eastern corporate limits of the city of Medina, & on the county road from the west corporate limits of Medina running due west to and through community of Risley to the western edge of Medina County - All territory south of this line), PORTAGE, and SUMMIT (S. of Rte. #303) COUNTIES

	Rates	Fringes
Plumber and Steamfitter.....	\$ 43.22	27.29

 PLUM0392-002 06/01/2023

BROWN, BUTLER, CLERMONT, HAMILTON & WARREN

	Rates	Fringes
PLUMBER/PIPEFITTER.....	\$ 38.62	25.83

 PLUM0396-001 06/01/2023

COLUMBIANA (Excluding Washington & Yellow Creek Townships & Liverpool Twp. - Secs. 35 & 36 - West of County Road #427), MAHONING and TRUMBULL COUNTIES

	Rates	Fringes
PLUMBER/PIPEFITTER.....	\$ 37.10	28.51

 PLUM0495-002 06/01/2023

CARROLL (Rose, Monroe, Union, Lee, Orange, Perry & Loudon Townships), COLUMBIANA (Washington & Yellow Creek Townships & Liverpool Township, Secs. 35 & 36, West of County Rd. #427), COSHOCTON, GUERNSEY, HARRISON, HOLMES, JEFFERSON, MORGAN (South to State Rte. #78 & from McConnelsville west on State Rte. #37 to the Perry County line), MUSKINGUM, NOBLE, and TUSCARAWAS COUNTIES

	Rates	Fringes
Plumber, Pipefitter, Steamfitter.....	\$ 32.23	35.40

 PLUM0577-002 06/01/2023

ADAMS, ATHENS, GALLIA, HIGHLAND, JACKSON, LAWRENCE, PIKE, SCIOTO & VINTON

	Rates	Fringes
Plumber, Pipefitter, Steamfitter.....	\$ 39.98	26.48

 PLUM0776-002 07/01/2023

ALLEN, AUGLAIZE, HARDIN, LOGAN, MERCER, SHELBY and VAN WERT COUNTIES

	Rates	Fringes
Plumber, Pipefitter, Steamfitter.....	\$ 40.07	28.95

 TEAM0377-003 05/01/2023

STATEWIDE, EXCEPT CUYAHOGA, GEAUGA & LAKE

Rates Fringes

TRUCK DRIVER

GROUP 1.....	\$ 31.49	16.40
GROUP 2.....	\$ 31.91	16.40

TRUCK DRIVER CLASSIFICATIONS

GROUP 1 - Asphalt Distributor; Batch; 4- Wheel Service; 4-Wheel Dump; Oil Distributor & Tandem

GROUP 2 - Tractor-Trailer Combination: Fuel; Pole Trailer; Ready Mix; Semi-Tractor; & Asphalt Oil Spraybar Man When Operated From Cab; 5 Axles & Over; Belly Dump; End Dump; Articulated Dump; Heavy Duty Equipment; Low Boy; & Truck Mechanic

TEAM0436-002 05/01/2023

CUYAHOGA, GEAUGA & LAKE

Rates Fringes

TRUCK DRIVER

GROUP 1.....	\$ 31.00	18.95
GROUP 2.....	\$ 32.50	18.95

GROUP 1: Straight & Dump, Straight Fuel

GROUP 2: Semi Fuel, Semi Tractor, Euclids, Darts, Tank, Asphalt Spreaders, Low Boys, Carry-All, Tourna-Rockers, Hi-Lifts, Extra Long Trailers, Semi-Pole Trailers, Double Hook-Up Tractor Trailers including Team Track & Railroad Siding, Semi-Tractor & Tri-Axle Trailer, Tandem Tractor & Tandem Trailer, Tag Along Trailer, Expandable Trailer or Towing Requiring Road Permits, Ready-Mix (Agitator or Non-Agitator), Bulk Concrete Driver, Dry Batch Truck, Articulated End Dump

WELDERS - Receive rate prescribed for craft performing operation to which welding is incidental.

=====
** Workers in this classification may be entitled to a higher minimum wage under Executive Order 14026 (\$17.20) or 13658 (\$12.90). Please see the Note at the top of the wage determination for more information. Please also note that the minimum wage requirements of Executive Order 14026 are not currently being enforced as to any contract or subcontract to which the states of Texas, Louisiana, or Mississippi, including their agencies, are a party.

Note: Executive Order (EO) 13706, Establishing Paid Sick Leave for Federal Contractors applies to all contracts subject to the Davis-Bacon Act for which the contract is awarded (and any solicitation was issued) on or after January 1, 2017. If this contract is covered by the EO, the contractor must provide employees with 1 hour of paid sick leave for every 30 hours they work, up to 56 hours of paid sick leave each year. Employees must be permitted to use paid sick leave for their own illness, injury or other health-related needs, including preventive care; to assist a family member (or person who is like family to the employee) who is ill, injured, or has other health-related needs, including preventive care; or for reasons

resulting from, or to assist a family member (or person who is like family to the employee) who is a victim of, domestic violence, sexual assault, or stalking. Additional information on contractor requirements and worker protections under the EO is available at <https://www.dol.gov/agencies/whd/government-contracts>.

Unlisted classifications needed for work not included within the scope of the classifications listed may be added after award only as provided in the labor standards contract clauses (29CFR 5.5 (a) (1) (iii)).

The body of each wage determination lists the classification and wage rates that have been found to be prevailing for the cited type(s) of construction in the area covered by the wage determination. The classifications are listed in alphabetical order of ""identifiers"" that indicate whether the particular rate is a union rate (current union negotiated rate for local), a survey rate (weighted average rate) or a union average rate (weighted union average rate).

Union Rate Identifiers

A four letter classification abbreviation identifier enclosed in dotted lines beginning with characters other than ""SU"" or ""UAVG"" denotes that the union classification and rate were prevailing for that classification in the survey. Example: PLUM0198-005 07/01/2014. PLUM is an abbreviation identifier of the union which prevailed in the survey for this classification, which in this example would be Plumbers. 0198 indicates the local union number or district council number where applicable, i.e., Plumbers Local 0198. The next number, 005 in the example, is an internal number used in processing the wage determination. 07/01/2014 is the effective date of the most current negotiated rate, which in this example is July 1, 2014.

Union prevailing wage rates are updated to reflect all rate changes in the collective bargaining agreement (CBA) governing this classification and rate.

Survey Rate Identifiers

Classifications listed under the ""SU"" identifier indicate that no one rate prevailed for this classification in the survey and the published rate is derived by computing a weighted average rate based on all the rates reported in the survey for that classification. As this weighted average rate includes all rates reported in the survey, it may include both union and non-union rates. Example: SULA2012-007 5/13/2014. SU indicates the rates are survey rates based on a weighted average calculation of rates and are not majority rates. LA indicates the State of Louisiana. 2012 is the year of survey on which these classifications and rates are based. The next number, 007 in the example, is an internal number used in producing the wage determination. 5/13/2014 indicates the survey completion date for the classifications and rates under that identifier.

Survey wage rates are not updated and remain in effect until a new survey is conducted.

Union Average Rate Identifiers

Classification(s) listed under the UAVG identifier indicate that no single majority rate prevailed for those classifications; however, 100% of the data reported for the

classifications was union data. EXAMPLE: UAVG-OH-0010
08/29/2014. UAVG indicates that the rate is a weighted union
average rate. OH indicates the state. The next number, 0010 in
the example, is an internal number used in producing the wage
determination. 08/29/2014 indicates the survey completion date
for the classifications and rates under that identifier.

A UAVG rate will be updated once a year, usually in January of
each year, to reflect a weighted average of the current
negotiated/CBA rate of the union locals from which the rate is
based.

WAGE DETERMINATION APPEALS PROCESS

1.) Has there been an initial decision in the matter? This can
be:

- * an existing published wage determination
- * a survey underlying a wage determination
- * a Wage and Hour Division letter setting forth a position on
a wage determination matter
- * a conformance (additional classification and rate) ruling

On survey related matters, initial contact, including requests
for summaries of surveys, should be with the Wage and Hour
National Office because National Office has responsibility for
the Davis-Bacon survey program. If the response from this
initial contact is not satisfactory, then the process described
in 2.) and 3.) should be followed.

With regard to any other matter not yet ripe for the formal
process described here, initial contact should be with the
Branch of Construction Wage Determinations. Write to:

Branch of Construction Wage Determinations
Wage and Hour Division
U.S. Department of Labor
200 Constitution Avenue, N.W.
Washington, DC 20210

2.) If the answer to the question in 1.) is yes, then an
interested party (those affected by the action) can request
review and reconsideration from the Wage and Hour Administrator
(See 29 CFR Part 1.8 and 29 CFR Part 7). Write to:

Wage and Hour Administrator
U.S. Department of Labor
200 Constitution Avenue, N.W.
Washington, DC 20210

The request should be accompanied by a full statement of the
interested party's position and by any information (wage
payment data, project description, area practice material,
etc.) that the requestor considers relevant to the issue.

3.) If the decision of the Administrator is not favorable, an
interested party may appeal directly to the Administrative
Review Board (formerly the Wage Appeals Board). Write to:

Administrative Review Board
U.S. Department of Labor
200 Constitution Avenue, N.W.
Washington, DC 20210

4.) All decisions by the Administrative Review Board are final.

END OF GENERAL DECISION"